

If the outboard motor's serial number plate contains the CE mark in the lower left-hand corner, the following statement applies:

This outboard motor manufactured by Mercury Marine, Fond du Lac, WI, USA or Marine Power Europe Inc. Park Industriel, de Petit-Rechain, Belgium complies with the requirements of the following directives and standards, as amended:

Recreational Craft Directive: 94/25/EC; std. ISO 8665, ISO 11547

Machinery Directive: 98/37/EC,

EMC Directive: 89/336/EC; std. EN50081-1, SAE J551 (CISPR Pub. 12), EN 50082-1, IEC 61000 PT4-2, IEC 61000 PT4-3



Patrick C. Mackey  
President, Mercury Marine, Fond du Lac, WI USA  
European Regulations Contact:  
Product Environmental Engineering Department, Mercury Marine,  
Fond du Lac, WI USA

## EPA Emissions Regulations

Outboards manufactured by Mercury Marine in the United States are certified to the United States Environmental Protection Agency as conforming to the requirements of the regulations for the control of air pollution from new outboard motors. This certification is contingent on certain adjustments being set to factory standards. For this reason, the factory procedure for servicing the product must be strictly followed and, wherever practicable, returned to the original intent of the design. **Maintenance, replacement, or repair of the emission control devices and systems may be performed by any marine engine repair establishment or individual.**

Engines are labeled with an Emission Control Information decal as permanent evidence of EPA certification.

### **WARNING**

**The engine exhaust from this product contains chemicals known to the state of California to cause cancer, birth defects or other reproductive harm.**

## Thank You

for your purchase of one of the finest outboards available. You have made a sound investment in boating pleasure. Your outboard has been manufactured by Mercury Marine, a world leader in marine technology and outboard manufacturing since 1939. These years of experience have been committed to the goal of producing the finest quality products. This led to Mercury Marine's reputation for strict quality control, excellence, durability, lasting performance and being the best at providing after the sale support. Please read this manual carefully before operating your outboard. This manual has been prepared to assist you in the operation, safe use and care of your outboard.

All of us at Mercury Marine took pride in building your outboard and wish you many years of happy and safe boating.

Again, thank you for your confidence in Mercury Marine.

## Warranty Message

The product you have purchased comes with a **limited warranty** from Mercury Marine, the terms of the warranty are set forth in the **Warranty Information** Section of this manual. The warranty statement contains a description of what is covered, what is not covered, the duration of coverage, how to best obtain warranty coverage, **important disclaimers and limitations of damages**, and other related information. Please review this important information.

The description and specifications contained herein were in effect at the time this manual was approved for printing. Mercury Marine, whose policy is one of continued improvement, reserves the right to discontinue models at any time, to change specifications, designs, methods, or procedures without notice and without incurring obligation.

Mercury Marine, Fond du Lac, Wisconsin U.S.A.

Litho in U.S.A.

© 2004, Mercury Marine

Mercury, Mercury Marine, MerCruiser, Mercury MerCruiser, Mercury Racing, Mercury Precision Parts, Mercury Propellers, Mariner, Quicksilver, #1 On The Water, Alpha, Bravo, Pro Max, OptiMax, Sport-Jet, K-Planes, MerCathode, RideGuide, SmartCraft, Zero Effort, M with Waves logo, Mercury with Waves logo, and SmartCraft logo are all registered trademarks of Brunswick Corporation. Mercury Product Protection logo is a registered service mark of Brunswick Corporation.

### **Mercury Premier Service**

Mercury evaluates the service performance of its dealers and assigns its highest rating of "Mercury Premier" to those demonstrating an exceptional commitment to service.

#### **Earning a Mercury Premier Service rating means a dealer:**

- Achieves a high 12 month service CSI (Customer Satisfaction Index) score for warranty service.
- Possesses all necessary service tools, test equipment, manuals and parts books.
- Employs at least one Certified or Master technician.
- Provides timely service for all Mercury Marine customers.
- Offers extended service hours and mobile service, when appropriate.
- Uses, displays and stocks adequate inventory of genuine Mercury Precision Parts.
- Offers a clean, neat shop with well organized tools and service literature.

# TABLE OF CONTENTS

---

## Warranty Information

---

Transfer Of Warranty.....	1
Warranty Registration United States And Canada.....	1
Warranty Registration Outside The United States And Canada.....	2
Four Stroke Outboard Limited Warranty.....	3
3 Year Limited Warranty Against Corrosion.....	6
Warranty Coverage And Exclusions.....	9
California Emissions Limited Warranty.....	11
Star Label.....	16

---

## General Information

---

Boater's Responsibilities.....	18
Before Operating Your Outboard.....	18
Boat Horsepower Capacity.....	18
High-Speed And High-Performance Boat Operation.....	19
Outboard Remote Control Models .....	19
Lanyard Stop Switch.....	19
Protecting People In The Water.....	21
Passenger Safety Message - Pontoon Boats And Deck Boats.....	22
Wave And Wake Jumping.....	23
Impact With Underwater Hazards.....	24
Exhaust Emissions.....	25
Selecting Accessories For Your Outboard.....	27
Safe Boating Suggestions.....	27
Recording Serial Number.....	29
Specifications.....	29
Component Identification.....	31

---

## Installation

---

Installing Outboard.....	32
Propeller Selection.....	34

---

## Transporting

---

Trailer Boat/Outboard .....	35
-----------------------------	----

---

# TABLE OF CONTENTS

---

## Fuel and Oil

---

Gasoline Recommendations.....	37
Filling Fuel Tank.....	38
Engine Oil Recommendations.....	38
Checking And Adding Engine Oil.....	39

---

## Features and Controls

---

Remote Control Features.....	42
Warning System.....	45
Power Trim and Tilt.....	49

---

## Operation

---

Pre-Starting Check List.....	54
Operating In Freezing Temperatures.....	54
Operating In Salt Water Or Polluted Water.....	54
Engine Break-in Procedure.....	55
Starting The Engine.....	55
Gear Shifting.....	64
Dual Helm Station Transfer.....	65
Synchronizing Dual Engines.....	66
Stopping The Engine.....	67
Remote Control Adjustments.....	68

---

## Maintenance

---

Outboard Care.....	69
EPA Regulations.....	69
EPA Emissions.....	70
Inspection And Maintenance Schedule.....	70
Flushing The Cooling System.....	72
Cowl Removal and Installation.....	73
Exterior Care.....	74
Battery Inspection .....	74
DTS Battery Specifications.....	75
Air Filter.....	76
Fuel System.....	78
Corrosion Control Anode.....	81

---

# TABLE OF CONTENTS

Propeller Replacement.....	82
Spark Plug Inspection and Replacement.....	84
Fuses.....	86
DTS Wiring System.....	87
Accessory Drive Belt Inspection.....	88
Checking Power Trim Fluid.....	88
Checking Power Steering Fluid.....	89
Changing Engine Oil .....	89
Gearcase Lubrication.....	92

---

## Storage

---

Storage Preparation.....	94
Protecting External Outboard Components.....	94
Protecting Internal Engine Components.....	95
Gearcase.....	95
Positioning Outboard For Storage.....	95
Battery Storage.....	95

---

## Troubleshooting

---

Starter Motor Will Not Crank the Engine.....	96
Engine Will Not Start.....	96
Engine Starts But Will Not Shift Into Gear.....	96
Engine Runs Erratically.....	96
Performance Loss.....	97
Battery Will Not Hold Charge.....	97

---

## Owner Service Assistance

---

Local Repair Service.....	98
Service Away From Home.....	98
Parts And Accessories Inquiries.....	98
Service Assistance.....	98
Mercury Marine Service Offices.....	99

---

## Maintenance Log

---

Maintenance Log.....	101
----------------------	-----

# WARRANTY INFORMATION

## Transfer Of Warranty

The limited warranty is transferable to a subsequent purchaser, but only for the remainder of the unused portion of the limited warranty. This will not apply to products used for commercial applications.

To transfer the warranty to the subsequent owner, send or fax a copy of the bill of sale or purchase agreement, new owner's name, address and engine serial number to Mercury Marine's warranty registration department.

Mercury Marine  
Attn: Warranty Registration Department  
W6250 W. Pioneer Road  
P.O. Box 1939  
Fond du Lac, WI 54936-1939  
920-929-5054

Upon processing the transfer of warranty, Mercury Marine will send registration verification to the new owner of the product by mail.

There is no charge for this service.

For products purchased outside the United States and Canada, contact the distributor in your country, or the Mercury Marine Service Office closest to you.

## Warranty Registration United States And Canada

1. You may change your address at any time, including at time of warranty claim, by calling Mercury Marine or sending a letter or fax with your name, old address, new address, and engine serial number to Mercury Marine's warranty registration department. Your dealer can also process this change of information.

Mercury Marine  
Attn: Warranty Registration Department  
W6250 W. Pioneer Road  
P.O. Box 1939  
Fond du Lac, WI 54936-1939  
920-929-5054

***NOTE: Registration lists must be maintained by Mercury Marine and any dealer on marine products sold in the United States, should a safety recall notification under the Federal Safety Act be required.***

# WARRANTY INFORMATION

2. To be eligible for warranty coverage, the product must be registered with Mercury Marine. At the time of sale, the dealer should complete the warranty registration and immediately submit it to Mercury Marine via MercNET, E-mail, or mail. Upon receipt of this warranty registration, Mercury Marine will record the registration.
3. Upon processing the warranty registration, Mercury Marine will send registration verification by mail to the purchaser of the product. If this registration verification is not received within 30 days, please contact your selling dealer immediately. Warranty coverage is not effective until your product is registered with Mercury Marine.

## Warranty Registration Outside The United States And Canada

1. It is important that your selling dealer fills out the Warranty Registration Card completely and mails it to the distributor or Marine Power Service Center responsible for administering the warranty registration/claim program for your area.
2. The Warranty Registration Card identifies your name and address, product model and serial numbers, date of sale, type of use and the selling distributor's/dealer's code number, name and address. The distributor/dealer also certifies that you are the original purchaser and user of the product.
3. A copy of the Warranty Registration Card, designated as the Purchaser's Copy, MUST be given to you immediately after the card has been completely filled out by the selling distributor/dealer. This card represents your factory registration identification, and should be retained by you for future use when required. Should you ever require warranty service on this product, your dealer may ask you for the Warranty Registration Card to verify date of purchase and to use the information on the card to prepare the warranty claim forms.
4. In some countries, the Marine Power Service Center will issue you a permanent (plastic) Warranty Registration Card within 30 days after receiving the Factory Copy of the Warranty Registration Card from your distributor/dealer. If you receive a plastic Warranty Registration Card, you may discard the Purchaser's Copy that you received from the distributor/dealer when you purchased the product. Ask your distributor/dealer if this plastic card program applies to you.



# WARRANTY INFORMATION

**IMPORTANT:** Registration lists must be maintained by the factory and dealer in some countries by law. It is our desire to have ALL products registered at the factory should it ever be necessary to contact you. Make sure your dealer/distributor fills out the warranty registration card immediately and sends the factory copy to the Marine Power International Service Center for your area.

5. For further information concerning the Warranty Registration Card and its relationship to Warranty Claim processing, refer to the International Warranty.

## Four Stroke Outboard Limited Warranty

### UNITED STATES AND CANADA

*Outside the United States and Canada - Check with your local distributor.*

*California residents that have purchased a 2001 model year outboard from a California dealer receive coverage in addition to that identified below for emissions related components. Please see the California Emission Warranty Statement provided by your dealer.*

**WHAT IS COVERED:** Mercury Marine warrants its new products to be free of defects in material and workmanship during the period described below.

**DURATION OF COVERAGE:** This Limited Warranty provides coverage for three (3) years from the date the product is first sold to a recreational use retail purchaser, or the date on which the product is first put into service, whichever occurs first. Commercial users of these products receive warranty coverage of one (1) year from the date of first retail sale, or one (1) year from the date on which the product was first put into service, whichever occurs first. Commercial use is defined as any work or employment related use of the product, or any use of the product which generates income, for any part of the warranty period, even if the product is only occasionally used for such purposes. The repair or replacement of parts, or the performance of service under this warranty, does not extend the life of this warranty beyond its original expiration date. Unexpired warranty coverage can be transferred from one recreational use customer to a subsequent recreational use customer upon proper re-registration of the product. Unexpired warranty coverage cannot be transferred either to or from a commercial use customer.

# WARRANTY INFORMATION

**CONDITIONS THAT MUST BE MET IN ORDER TO OBTAIN WARRANTY COVERAGE:** Warranty coverage is available only to retail customers that purchase from a Dealer authorized by Mercury Marine to distribute the product in the country in which the sale occurred, and then only after the Mercury Marine specified pre-delivery inspection process is completed and documented. Warranty coverage becomes available upon proper registration of the product by the authorized dealer. Inaccurate warranty registration information regarding recreational use, or subsequent change of use from recreational to commercial (unless properly re-registered) may void the warranty at the sole discretion of Mercury Marine. Routine maintenance outlined in the Operation and Maintenance Manual must be timely performed in order to maintain warranty coverage. Mercury Marine reserves the right to make warranty coverage contingent upon proof of proper maintenance.

**WHAT MERCURY WILL DO:** Mercury's sole and exclusive obligation under this warranty is limited to, at our option, repairing a defective part, replacing such part or parts with new or Mercury Marine certified re-manufactured parts, or refunding the purchase price of the Mercury product. Mercury reserves the right to improve or modify products from time to time without assuming an obligation to modify products previously manufactured.

**HOW TO OBTAIN WARRANTY COVERAGE:** The customer must provide Mercury with a reasonable opportunity to repair, and reasonable access to the product for warranty service. Warranty claims shall be made by delivering the product for inspection to a Mercury dealer authorized to service the product. If purchaser cannot deliver the product to such a dealer, written notice must be given to Mercury. We will then arrange for the inspection and any covered repair. Purchaser in that case shall pay for all related transportation charges and/or travel time. If the service provided is not covered by this warranty, purchaser shall pay for all related labor and material, and any other expenses associated with that service. Purchaser shall not, unless requested by Mercury, ship the product or parts of the product directly to Mercury. Proof of registered ownership must be presented to the dealer at the time warranty service is requested in order to obtain coverage.

**U.S. EPA EMISSIONS LIMITED WARRANTY:** Consistent with the obligations created by 40 CFR Part 91, Subpart M, Mercury Marine provides a two year limited warranty to the retail purchaser, that the engine is designed, built, and equipped so as to conform at the time of sale with applicable regulations under section 213 of the Clean Air Act, and that the engine is free from defects in materials and workmanship which cause the engine to fail to conform with applicable regulations.

# WARRANTY INFORMATION

**WHAT IS NOT COVERED:** This limited warranty does not cover routine maintenance items, tune ups, adjustments, normal wear and tear, damage caused by abuse, abnormal use, use of a propeller or gear ratio that does not allow the engine to run in its recommended wide open throttle RPM range (see the Operation and Maintenance Manual), operation of the product in a manner inconsistent with the recommended operation/duty cycle section of the Operation and Maintenance Manual, neglect, accident, submersion, improper installation (proper installation specifications and techniques are set forth in the installation instructions for the product), improper service, use of an accessory or part not manufactured or sold by us, jet pump impellers and liners, operation with fuels, oils or lubricants which are not suitable for use with the product (see the Operation and Maintenance Manual), alteration or removal of parts, water entering the engine through the fuel intake, air intake or exhaust system, or damage to the product from insufficient cooling water caused by blockage of the cooling system by a foreign body, running the engine out of water, mounting the engine too high on the transom, or running the boat with the engine trimmed out too far. Use of the product for racing or other competitive activity, or operating with a racing type lower unit, at any point, even by a prior owner of the product, voids the warranty.

Expenses related to haul out, launch, towing, storage, telephone, rental, inconvenience, slip fees, insurance coverage, loan payments, loss of time, loss of income, or any other type of incidental or consequential damages are not covered by this warranty. Also, expenses associated with the removal and/or replacement of boat partitions or material caused by boat design for access to the product are not covered by this warranty.

No individual or entity, including Mercury Marine authorized dealers, has been given authority by Mercury Marine to make any affirmation, representation or warranty regarding the product, other than those contained in this limited warranty, and if made, shall not be enforceable against Mercury Marine.

For additional information regarding events and circumstances covered by this warranty, and those that are not, see the Warranty Coverage section of the Operation and Maintenance Manual, incorporated by reference into this warranty.

# WARRANTY INFORMATION

## DISCLAIMERS AND LIMITATIONS:

THE IMPLIED WARRANTIES OF MERCHANTABILITY AND FITNESS FOR A PARTICULAR PURPOSE ARE EXPRESSLY DISCLAIMED. TO THE EXTENT THAT THEY CANNOT BE DISCLAIMED, THE IMPLIED WARRANTIES ARE LIMITED IN DURATION TO THE LIFE OF THE EXPRESS WARRANTY. INCIDENTAL AND CONSEQUENTIAL DAMAGES ARE EXCLUDED FROM COVERAGE UNDER THIS WARRANTY. SOME STATES/COUNTRIES DO NOT ALLOW FOR THE DISCLAIMERS, LIMITATIONS AND EXCLUSIONS IDENTIFIED ABOVE, AS A RESULT, THEY MAY NOT APPLY TO YOU. THIS WARRANTY GIVES YOU SPECIFIC LEGAL RIGHTS, AND YOU MAY ALSO HAVE OTHER LEGAL RIGHTS WHICH VARY FROM STATE TO STATE AND COUNTRY TO COUNTRY.

## 3 Year Limited Warranty Against Corrosion

**WHAT IS COVERED:** Mercury Marine warrants that each new Mercury, Mariner, Mercury Racing, Sport Jet, M<sup>2</sup> Jet Drive, Tracker by Mercury Marine Outboard, MerCruiser Inboard or sterndrive engine (Product) will not be rendered inoperative as a direct result of corrosion for the period of time described below.

**DURATION OF COVERAGE:** This limited corrosion warranty provides coverage for three (3) years from either the date the product is first sold, or the date on which the product is first put into service, whichever occurs first. The repair or replacement of parts, or the performance of service under this warranty does not extend the life of this warranty beyond its original expiration date. Unexpired warranty coverage can be transferred to subsequent (non-commercial use) purchaser upon proper re-registration of the product.

# WARRANTY INFORMATION

**CONDITIONS THAT MUST BE MET IN ORDER TO OBTAIN WARRANTY COVERAGE:** Warranty coverage is available only to retail customers that purchase from a Dealer authorized by Mercury Marine to distribute the product in the country in which the sale occurred, and then only after the Mercury Marine specified pre-delivery inspection process is completed and documented. Warranty coverage becomes available upon proper registration of the product by the authorized dealer. Corrosion prevention devices specified in the Operation and Maintenance Manual must be in use on the boat, and routine maintenance outlined in the Operation and Maintenance Manual must be timely performed (including without limitation the replacement of sacrificial anodes, use of specified lubricants, and touch-up of nicks and scratches) in order to maintain warranty coverage. Mercury Marine reserves the right to make warranty coverage contingent upon proof of proper maintenance.

**WHAT MERCURY WILL DO:** Mercury's sole and exclusive obligation under this warranty is limited to, at our option, repairing a corroded part, replacing such part or parts with new or Mercury Marine certified re-manufactured parts, or refunding the purchase price of the Mercury product. Mercury reserves the right to improve or modify products from time to time without assuming an obligation to modify products previously manufactured.

**HOW TO OBTAIN WARRANTY COVERAGE:** The customer must provide Mercury with a reasonable opportunity to repair, and reasonable access to the product for warranty service. Warranty claims shall be made by delivering the product for inspection to a Mercury dealer authorized to service the product. If purchaser cannot deliver the product to such a dealer, written notice must be given to Mercury. We will then arrange for the inspection and any covered repair. Purchaser in that case shall pay for all related transportation charges and/or travel time. If the service provided is not covered by this warranty, purchaser shall pay for all related labor and material, and any other expenses associated with that service. Purchaser shall not, unless requested by Mercury, ship the product or parts of the product directly to Mercury. Proof of registered ownership must be presented to the dealer at the time warranty service is requested in order to obtain coverage.

# WARRANTY INFORMATION

**WHAT IS NOT COVERED:** This limited warranty does not cover electrical system corrosion; corrosion resulting from damage, corrosion which causes purely cosmetic damage, abuse or improper service; corrosion to accessories, instruments, steering systems; corrosion to factory installed jet drive unit; damage due to marine growth; product sold with less than a one year limited Product warranty; replacement parts (parts purchased by customer); products used in a commercial application. Commercial use is defined as any work or employment related use of the product, or any use of the product which generates income, for any part of the warranty period, even if the product is only occasionally used for such purposes.

Corrosion damage caused by stray electrical currents (on-shore power connections, nearby boats, submerged metal) is not covered by this corrosion warranty and should be protected against by the use of a corrosion protection system, such as the Mercury Precision Parts or Quicksilver MerCathode system and/or Galvanic Isolator. Corrosion damage caused by improper application of copper base anti-fouling paints is also not covered by this limited warranty. If anti-fouling protection is required, Tri-Butyl-Tin-Adipate (TBTA) base anti-fouling paints are recommended on Outboard and MerCruiser boating applications. In areas where TBTA base paints are prohibited by law, copper base paints can be used on the hull and transom. Do not apply paint to the outboard or MerCruiser product. In addition, care must be taken to avoid an electrical interconnection between the warranted product and the paint. For MerCruiser product, an unpainted gap of at least 38 mm (1.5 in.) should be left around the transom assembly. Refer to the Operation and Maintenance Manual for additional details.

For additional information regarding events and circumstances covered by this warranty, and those that are not, see the Warranty Coverage section of the Operation and Maintenance Manual, incorporated by reference into this warranty.

# WARRANTY INFORMATION

## DISCLAIMERS AND LIMITATIONS:

THE IMPLIED WARRANTIES OF MERCHANTABILITY AND FITNESS FOR A PARTICULAR PURPOSE ARE EXPRESSLY DISCLAIMED. TO THE EXTENT THAT THEY CANNOT BE DISCLAIMED, THE IMPLIED WARRANTIES ARE LIMITED IN DURATION TO THE LIFE OF THE EXPRESS WARRANTY. INCIDENTAL AND CONSEQUENTIAL DAMAGES ARE EXCLUDED FROM COVERAGE UNDER THIS WARRANTY. SOME STATES/COUNTRIES DO NOT ALLOW FOR THE DISCLAIMERS, LIMITATIONS AND EXCLUSIONS IDENTIFIED ABOVE, AS A RESULT, THEY MAY NOT APPLY TO YOU. THIS WARRANTY GIVES YOU SPECIFIC LEGAL RIGHTS, AND YOU MAY ALSO HAVE OTHER LEGAL RIGHTS WHICH VARY FROM STATE TO STATE AND COUNTRY TO COUNTRY.

## Warranty Coverage And Exclusions

The purpose of this section is to help eliminate some of the more common misunderstandings regarding warranty coverage. The following information explains some of the types of services that are not covered by warranty. The provisions set forth following have been incorporated by reference into the Three Year Limited Warranty Against Corrosion Failure, the International Limited Outboard Warranty, and the United States and Canada Limited Outboard Warranty.

Keep in mind that warranty covers repairs that are needed within the warranty period because of defects in material and workmanship. Installation errors, accidents, normal wear, and a variety of other causes that affect the product are not covered.

Warranty is limited to defects in material or workmanship, but only when the consumer sale is made in the country to which distribution is authorized by us.

Should you have any questions concerning warranty coverage, contact your authorized dealer. They will be pleased to answer any questions that you may have.

## GENERAL EXCLUSIONS FROM WARRANTY

1. Minor adjustments and tune-ups, including checking, cleaning or adjusting spark plugs, ignition components, carburetor settings, filters, belts, controls, and checking lubrication made in connection with normal services.

# WARRANTY INFORMATION

2. Factory installed jet drive units - Specific parts excluded from the warranty are: The jet drive impeller and jet drive liner damaged by impact or wear, and water damaged drive shaft bearings as a result of improper maintenance.
3. Damage caused by neglect, lack of maintenance, accident, abnormal operation or improper installation or service.
4. Haul out, launch, towing charges, removal and/or replacement of boat partitions or material because of boat design for necessary access to the product, all related transportation charges and/or travel time, etc. Reasonable access must be provided to the product for warranty service. Customer must deliver product to an authorized dealer.
5. Additional service work requested by customer other than that necessary to satisfy the warranty obligation.
6. Labor performed by other than an authorized dealer may be covered only under following circumstances: When performed on emergency basis (providing there are no authorized dealers in the area who can perform the work required or have no facilities to haul out, etc., and prior factory approval has been given to have the work performed at this facility).
7. All incidental and/or consequential damages (storage charges, telephone or rental charges of any type, inconvenience or loss of time or income) are the owner's responsibility.
8. Use of other than Mercury Precision or Quicksilver parts when making warranty repairs.
9. Oils, lubricants or fluids changed as a matter of normal maintenance is customer's responsibility unless loss or contamination of same is caused by product failure that would be eligible for warranty consideration.
10. Participating in or preparing for racing or other competitive activity or operating with a racing type lower unit.
11. Engine noise does not necessarily indicate a serious engine problem. If diagnosis indicates a serious internal engine condition which could result in a failure, condition responsible for noise should be corrected under the warranty.
12. Lower unit and/or propeller damage caused by striking a submerged object is considered a marine hazard.
13. Water entering engine through the fuel intake, air intake or exhaust system or submersion.
14. Failure of any parts caused by lack of cooling water, which results from starting motor out of water, foreign material blocking inlet holes, motor being mounted too high or trimmed too far out.



# WARRANTY INFORMATION

15. Use of fuels and lubricants which are not suitable for use with or on the product. Refer to the **Maintenance** section.
16. Our limited warranty does not apply to any damage to our products caused by the installation or use of parts and accessories which are not manufactured or sold by us. Failures which are not related to the use of those parts or accessories are covered under warranty if they otherwise meet the terms of the limited warranty for that product.

## California Emissions Limited Warranty

The California Air Resources Board has promulgated air emissions regulations for outboard engines. The regulations apply to all outboard engines sold to retail consumers in California, and which were manufactured for the 2001 model year, and later. Mercury Marine, in compliance with those regulations, provides this limited warranty for the emission control systems (see the components of the emission control system listed following), and further warrants that the outboard engine was designed, built and equipped to conform with all applicable regulations adopted by the California Air Resources Board pursuant to its authority in Chapters 1 and 2, Part 5, Division 26 of the Health and Safety Code. For information regarding the limited warranty for the non emissions related components of the outboard, please see the limited warranty statement for your outboard.

**WHAT IS COVERED:** Mercury Marine warrants the components of the emissions control systems (see the components of the emission control system listed following) of its new, 2001 model year (and later) outboards, sold by a California dealer to retail customers residing in California, to be free from defects in material or workmanship, that cause the failure of a warranted part to be identical in all material respects to that part as described in the application of Mercury Marine for certification from the California Air Resources Board, for the period of time, and under the conditions, identified below. The cost to diagnose a warranty failure is covered under the warranty (if the warranty claim is approved). Damage to other engine components caused by the failure of a warranted part will also be repaired under warranty.

# WARRANTY INFORMATION

**DURATION OF COVERAGE:** This limited warranty provides coverage for the components of the emissions control systems of new, 2001 model year (and later) outboards, sold to retail customers in California for 4 years from either the date the product is first sold, or first put into service, whichever occurs first, or the accumulation of 250 hours of engine operation (as determined by the engines hour meter, if any). Emission related normal maintenance items such as spark plugs and filters, that are on the warranted parts list (see following) are warranted up to their first required replacement interval only. (See **Maintenance - Inspection and Maintenance Schedule**). The repair or replacement of parts, or the performance of service under this warranty, does not extend the life of this warranty beyond its original expiration date. Unexpired warranty coverage can be transferred to a subsequent purchaser. (See instructions on transfer of warranty).

**HOW TO OBTAIN WARRANTY COVERAGE:** The customer must provide Mercury with a reasonable opportunity to repair, and reasonable access to the product for warranty service. Warranty claims shall be made by delivering the product for inspection to a Mercury dealer authorized to service the product. If purchaser cannot deliver the product to such a dealer, please notify Mercury Marine and Mercury will then arrange for the inspection and any covered repair. Purchaser in that case shall pay for all related transportation charges and/or travel time. If the service provided is not covered by this warranty, purchaser shall pay for all related labor and material, and any other expenses associated with that service. Purchaser shall not, unless requested by Mercury, ship the product or parts of the product directly to Mercury.

**WHAT MERCURY WILL DO:** Mercury Marine's sole and exclusive obligation under this warranty is limited to, at our expense and at our option, repairing or replacing defective parts with new or Mercury Marine certified re-manufactured parts, or refunding the purchase price of the Mercury product. Mercury reserves the right to improve or modify products from time to time without assuming an obligation to modify products previously manufactured.

# WARRANTY INFORMATION

**WHAT IS NOT COVERED:** This limited warranty does not cover routine maintenance items, tune ups, adjustments, normal wear and tear, damage caused by abuse, abnormal use, use of a propeller or gear ratio that does not allow the engine to run in its recommended wide open throttle RPM range (see **General Information - Specifications**), operation of the product in a manner inconsistent with the recommended operation procedures, neglect, accident, submersion, improper installation (proper installation specifications and techniques are set forth in the installation instructions for the product), improper service, use of an accessory or part not manufactured or sold by us, jet pump impellers and liners, operation with fuels, oils or lubricants which are not suitable for use with the product (see **Fuel and Oil**), alteration or removal of parts, or water entering the engine through the fuel intake, air intake or exhaust system. Use of the product for racing or other competitive activity, or operating with a racing type lower unit, at any point, even by a prior owner of the product, voids the warranty.

Expenses related to haul out, launch, towing, storage, telephone, rental, inconvenience, slip fees, insurance coverage, loan payments, loss of time, loss of income, or any other type of incidental or consequential damages are not covered by this warranty. Also, expenses associated with the removal and/or replacement of boat partitions or material caused by boat design for access to the product are not covered by this warranty.

Non-warranty maintenance, replacement, or repair of emission control devices and systems may be performed by any marine engine repair establishment or individual. The use of non-Mercury parts for non-warranty maintenance or repairs will not be grounds for disallowing other warranty work. The use of add-on (as defined at section 1900 (b)(1) and (b)(10) of Title 13 of the California Code of Regulations) or modified parts not exempted by the California Air Resources Board may be grounds for disallowing a warranty claim, at the discretion of Mercury Marine. Failures of warranted parts caused by the use of a non-exempted add-on or modified part will not be covered.

## COMPONENTS OF THE EMISSIONS CONTROL SYSTEM:

1. Fuel Metering System
  - a. Carburetor and internal parts (and/or pressure regulator or fuel injection system)
  - b. Cold start enrichment system
  - c. Intake valves
2. Air Induction System
  - a. Intake manifold
  - b. Turbocharger or supercharger systems (where applicable)

# WARRANTY INFORMATION

3. Ignition System
  - a. Spark plugs
  - b. Magneto or electronic ignition system
  - c. Spark advance/retard system
  - d. Ignition coil and/or control module
  - e. Ignition wires
4. Lubrication System (4-Stroke engines excluded)
  - a. Oil pump and internal parts
  - b. Oil injectors
  - c. Oil meter
5. Exhaust system
  - a. Exhaust manifold
  - b. Exhaust valves
6. Miscellaneous Items Used in Above Systems
  - a. Hoses, clamps, fittings, tubing, sealing gaskets or devices, and mounting hardware.
  - b. Pulleys, belts and idlers.
  - c. Vacuum, temperature, check and time sensitive valves and switches
  - d. Electronic controls.

## DISCLAIMERS AND LIMITATIONS

THE IMPLIED WARRANTIES OF MERCHANTABILITY AND FITNESS FOR A PARTICULAR PURPOSE ARE EXPRESSLY DISCLAIMED. TO THE EXTENT THAT THEY CANNOT BE DISCLAIMED, THE IMPLIED WARRANTIES ARE LIMITED IN DURATION TO THE LIFE OF THE EXPRESS WARRANTY. INCIDENTAL AND CONSEQUENTIAL DAMAGES ARE EXCLUDED FROM COVERAGE UNDER THIS WARRANTY. SOME STATES/COUNTRIES DO NOT ALLOW FOR THE DISCLAIMERS, LIMITATIONS AND EXCLUSIONS IDENTIFIED ABOVE, AS A RESULT, THEY MAY NOT APPLY TO YOU. THIS WARRANTY GIVES YOU SPECIFIC LEGAL RIGHTS, AND YOU MAY ALSO HAVE OTHER LEGAL RIGHTS WHICH VARY FROM STATE TO STATE AND COUNTRY TO COUNTRY.

If you have any questions regarding your warranty rights and responsibilities, you should contact Mercury Marine at 1-920-929-5040.

# WARRANTY INFORMATION

## CALIFORNIA AIR RESOURCES BOARD EXPLANATION OF YOUR CALIFORNIA EMISSION CONTROL WARRANTY STATEMENT

**YOUR WARRANTY RIGHTS AND OBLIGATIONS:** The California Air Resources Board is pleased to explain the emission control system warranty on your 2001 model year and later outboard engine. In California, new outboard engines must be designed, built and equipped to meet the State's stringent anti-smog standards. Mercury Marine must warrant the emission control system on your outboard engine for the periods of time listed below provided there has been no abuse, neglect or improper maintenance of your outboard engine.

Your emission control system may include parts such as the carburetor or fuel injection system, the ignition system, and catalytic converter. Also included may be hoses, belts, connectors and other emission-related assemblies.

Where a warrantable condition exists, Mercury Marine will repair your outboard engine at no cost to you, including diagnosis, parts and labor.

**MANUFACTURER'S WARRANTY COVERAGE:** Select emission control parts from model year 2001 and later outboard engines are warranted for 4 years, or for 250 hours of use, whichever occurs first. However, warranty coverage based on the hourly period is only permitted for outboard engines and personal watercraft equipped with appropriate hour meters or their equivalent. If any emission related part on your engine is defective under warranty, the part will be repaired or replaced by Mercury Marine.

**OWNER'S WARRANTY RESPONSIBILITIES:** As the outboard engine owner, you are responsible for the performance of the required maintenance listed in the Maintenance section. Mercury Marine recommends that you retain all receipts covering maintenance on your outboard engine, but Mercury Marine cannot deny warranty solely for the lack of receipts or your failure to ensure the performance of all scheduled maintenance.

As the outboard engine owner, you should however be aware that Mercury Marine may deny you warranty coverage if your outboard engine or a part has failed due to abuse, neglect, improper maintenance or unapproved modifications.

You are responsible for presenting your outboard to a Mercury dealer authorized to service the product as soon as a problem exists. The warranty repairs will be completed in a reasonable amount of time, not to exceed 30 days.

If you have any questions regarding your warranty rights and responsibilities, you should contact Mercury Marine at 1-920-929-5040.

# WARRANTY INFORMATION

## Star Label



Outboards are labeled on the cowl with one of the following star labels.

### The Symbol for Cleaner Marine Engines Means:

**Cleaner Air and Water** - for a healthier lifestyle and environment.

**Better Fuel Economy** - burns up to 30-40 percent less gas and oil than conventional carbureted two-stroke engines, saving money and resources.

**Longer Emission Warranty** - Protects consumer for worry free operation.

 The logo features a single star in the center of an oval. Above the star, the text "LOW" is written in a curved banner. Below the star, the text "EMISSION" is written in a curved banner. In the background, smaller text reads "CALIFORNIA EMISSION STANDARDS". To the right of the logo is the code "ob00708". <p>ob00708</p>	<p><b>One Star - Low Emission</b></p> <p>The one Star Label identifies engines that meet the Air Resources Board's 2001 exhaust emissions standards. Engines meeting these standards have 75% lower emissions than conventional carbureted two-stroke engines. These engines are equivalent to the U.S. EPA's 2006 standards for marine engines.</p>
 The logo features two stars in the center of an oval. Above the stars, the text "VERY LOW" is written in a curved banner. Below the stars, the text "EMISSION" is written in a curved banner. In the background, smaller text reads "CALIFORNIA EMISSION STANDARDS". To the right of the logo is the code "ob00709". <p>ob00709</p>	<p><b>Two Stars - Very Low Emission</b></p> <p>The two Star Label identifies engines that meet the Air Resources Board's Personal Watercraft and Outboard marine engine 2004 exhaust emissions standards. Engines meeting these standards have 20% lower emissions than One Star - Low Emission engines.</p>
 The logo features three stars in the center of an oval. Above the stars, the text "ULTRA LOW" is written in a curved banner. Below the stars, the text "EMISSION" is written in a curved banner. In the background, smaller text reads "CALIFORNIA EMISSION STANDARDS". To the right of the logo is the code "ob00710". <p>ob00710</p>	<p><b>Three Stars - Ultra Low Emission</b></p> <p>The three Star Label identifies engines that meet the Air Resources Board's personal Watercraft and Outboard marine engine 2008 exhaust emissions standards or the Sterndrive and Inboard marine engine 2003-2008 exhaust emission standards. Engines meeting these standards have 65% lower emissions than One Star - Low Emission engines.</p>

# WARRANTY INFORMATION



ob00711

## Four Stars - Super Ultra Low Emission

The four Star label identifies engines that meet the Air Resources Board's Stern-drive and Inboard marine engine 2009 exhaust emission standards. Personal Watercraft and Outboard marine engines may also comply with these standards. Engines meeting these standards have 90% lower emissions than One Star - Low Emission engines.

# GENERAL INFORMATION

## Boater's Responsibilities

The operator (driver) is responsible for the correct and safe operation of the boat and safety of its occupants and general public. It is strongly recommended that each operator (driver) read and understand this entire manual before operating the outboard.

Be sure at least one additional person on board is instructed in the basics of starting and operating the outboard and boat handling in case the driver is unable to operate the boat.

## Before Operating Your Outboard

Read this manual carefully. Learn how to operate your outboard properly. If you have any questions, contact your dealer.

Safety and operating information that is practiced, along with using good common sense, can help prevent personal injury and product damage.

This manual as well as safety labels posted on the outboard use the following safety alerts to draw your attention to special safety instructions that should be followed.

### **DANGER**

**DANGER** - indicates an imminently hazardous situation that, if not avoided, will result in death or serious injury.

### **WARNING**

**WARNING** - indicates a potentially hazardous situation that, if not avoided, could result in death or serious injury.

### **CAUTION**

**CAUTION** - indicates a potentially hazardous situation that, if not avoided, may result in minor or moderate injury or property damage. It may also be used to alert against unsafe practices.

## Boat Horsepower Capacity

### **WARNING**

Using an outboard that exceeds the maximum horsepower limit of a boat can: 1) cause loss of boat control 2) place too much weight at the transom altering the designed flotation characteristics of the boat or 3) cause the boat to break apart particularly around the transom area. Overpowering a boat can result in serious injury, death or boat damage.



# GENERAL INFORMATION

Do not overpower or overload your boat. Most boats will carry a required capacity plate indicating the maximum acceptable power and load as determined by the manufacturer following certain federal guidelines. If in doubt, contact your dealer or the boat manufacturer.

U.S. COAST GUARD CAPACITY	
MAXIMUM HORSEPOWER	XXX
MAXIMUM PERSON CAPACITY (POUNDS)	XXX
MAXIMUM WEIGHT CAPACITY	XXX

ob00306

## High-Speed And High-Performance Boat Operation

If your outboard is to be used on a high speed or high performance boat with which you are unfamiliar, we recommend that you never operate it at its high speed capability without first requesting an initial orientation and familiarization demonstration ride with your dealer or an operator experienced with your boat/outboard combination. For additional information, obtain a copy of our **Hi-Performance Boat Operation** booklet (part number 90-849250--1) from your dealer, distributor, or Mercury Marine.



ob00307

## Outboard Remote Control Models

The outboard must be equipped with a Mercury remote control designed for digital throttle and shift. Start-in-gear protection is provided by the remote control system.

## Lanyard Stop Switch

The purpose of a lanyard stop switch is to turn off the engine when the operator moves far enough away from the operator's position (as in accidental ejection from the operator's position) to activate the switch. Tiller handle outboards and some remote control units are equipped with a lanyard stop switch. A lanyard stop switch can be installed as an accessory - generally on the dashboard or side adjacent to the operator's position.

# GENERAL INFORMATION

The lanyard is a cord usually between 122 and 152 cm (4 and 5 feet) in length when stretched out, with an element on one end made to be inserted into the switch and a snap on the other end for attaching to the operator. The lanyard is coiled to make its at-rest condition as short as possible to minimize the likelihood of lanyard entanglement with nearby objects. Its stretched-out length is made to minimize the likelihood of accidental activation should the operator choose to move around in an area close to the normal operator's position. If it is desired to have a shorter lanyard, wrap the lanyard around the operator's wrist or leg, or tie a knot in the lanyard.

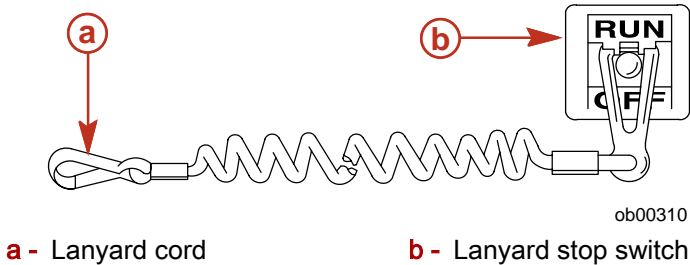

Read the following Safety Information before proceeding.

**Important Safety Information:** The purpose of a lanyard stop switch is to stop the engine when the operator moves far enough away from the operator's position to activate the switch. This would occur if the operator accidentally falls overboard or moves within the boat a sufficient distance from the operator's position. Falling overboard and accidental ejections are more likely to occur in certain types of boats such as low sided inflatables, bass boats, high performance boats, and light, sensitive handling fishing boats operated by a hand tiller. Falling overboard and accidental ejections are also likely to occur as a result of poor operating practices such as sitting on the back of the seat or gunwale at planing speeds, standing at planing speeds, sitting on elevated fishing boat decks, operating at planing speeds in shallow or obstacle infested waters, releasing your grip on a steering wheel or tiller handle that is pulling in one direction, drinking alcohol or consuming drugs, or daring high speed boat maneuvers.

While activation of the lanyard stop switch will stop the engine immediately, a boat will continue to coast for some distance depending upon the velocity and degree of any turn at shut down. However, the boat will not complete a full circle. While the boat is coasting, it can cause injury to anyone in the boat's path as seriously as the boat would when under power.

We strongly recommend that other occupants be instructed on proper starting and operating procedures should they be required to operate the engine in an emergency (e.g. if the operator is accidentally ejected).

# GENERAL INFORMATION

## **⚠ WARNING**

Should the operator fall out of the boat, the possibility of serious injury or death from being run over by the boat can be greatly reduced by stopping the engine immediately. Always properly connect both ends of the stop switch lanyard to the stop switch and the operator.

## **⚠ WARNING**

Avoid serious injury or death from deceleration forces resulting from accidental or unintended stop switch activation. The boat operator should never leave the operator's station without first disconnecting the stop switch lanyard from the operator.

Accidental or unintended activation of the switch during normal operation is also a possibility. This could cause any, or all, of the following potentially hazardous situations:

- Occupants could be thrown forward due to unexpected loss of forward motion - a particular concern for passengers in the front of the boat who could be ejected over the bow and possibly struck by the gearcase or propeller.
- Loss of power and directional control in heavy seas, strong current or high winds.
- Loss of control when docking.

## Protecting People In The Water

### WHILE YOU ARE CRUISING

It is very difficult for a person standing or floating in the water to take quick action to avoid a boat heading in his/her direction, even at slow speed.



ob00311

Always slow down and exercise extreme caution any time you are boating in an area where there might be people in the water.

Whenever a boat is moving (coasting) and the outboard gear shift is in neutral position, there is sufficient force by the water on the propeller to cause the propeller to rotate. This neutral propeller rotation can cause serious injury.

# GENERAL INFORMATION

## WHILE BOAT IS STATIONARY

### WARNING

Stop your engine immediately whenever anyone in the water is near your boat. Serious injury to the person in the water is likely if contacted by a rotating propeller, a moving boat, a moving gearcase, or any solid device rigidly attached to a moving boat or gearcase.

Shift outboard into neutral and shut off the engine before allowing people to swim or be in the water near your boat.

## Passenger Safety Message - Pontoon Boats And Deck Boats

Whenever the boat is in motion, observe the location of all passengers. Do not allow any passengers to stand or use seats other than those designated for traveling faster than idle speed. A sudden reduction in boat speed, such as plunging into a large wave or wake, a sudden throttle reduction, or a sharp change of boat direction, could throw them over the front of boat. Falling over the front of the boat between the two pontoons will position them to be run over by the outboard.

### BOATS HAVING AN OPEN FRONT DECK

No one should ever be on the deck in front of the fence while the boat is in motion. Keep all passengers behind the front fence or enclosure.

Persons on the front deck could easily be thrown overboard or persons dangling their feet over the front edge could get their legs caught by a wave and pulled into the water.

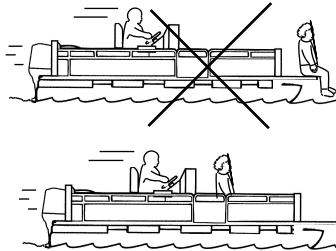

ob00312

### WARNING

Avoid serious injury or death from falling over the front end of a pontoon or deck boat and being run over by the outboard. Stay back from the front end of the deck and remain seated while the boat is in motion.

# GENERAL INFORMATION

## BOATS WITH FRONT MOUNTED, RAISED PEDESTAL FISHING SEATS

Elevated fishing seats are not intended for use when the boat is traveling faster than idle or trolling speed. Sit only in seats designated for traveling at faster speeds.

Any unexpected, sudden reduction in boat speed could result in the elevated passenger falling over the front of the boat.

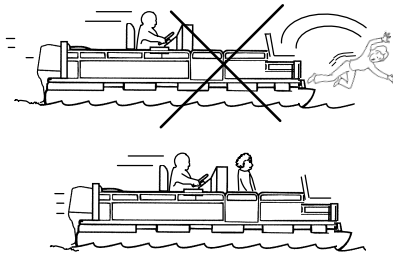

ob00313

## Wave And Wake Jumping

Operating recreational boats over waves and wake is a natural part of boating. However, when this activity is done with sufficient speed to force the boat hull partially or completely out of the water, certain hazards arise, particularly when the boat re-enters the water.

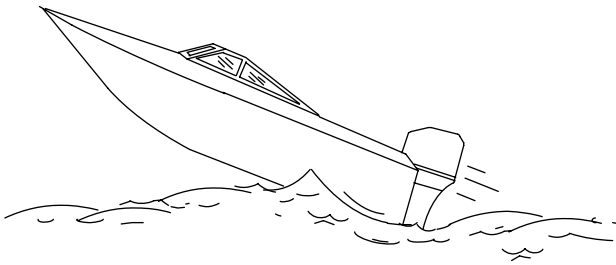

ob00314

The primary concern is the boat changing direction while in the midst of the jump. In such case the landing may cause the boat to veer violently in a new direction. Such a sharp change in direction can cause occupants to be thrown out of their seats, or out of the boat.

### **WARNING**

**Avoid serious injury or death from being thrown within or out of a boat when it lands after jumping a wave or wake. Avoid wave or wake jumping whenever possible. Instruct all occupants that if a wake or wave jump occurs, get low and hang on to a boat hand hold.**

# GENERAL INFORMATION

There is another less common hazardous result from allowing your boat to launch off a wave or wake. If the bow of your boat pitches down far enough while airborne, upon water contact it may penetrate under the water surface and submarine for an instant. This will bring the boat to a nearly instantaneous stop and can send the occupants flying forward. The boat may also steer sharply to one side.

## Impact With Underwater Hazards

Reduce speed and proceed with caution whenever you drive a boat in shallow water areas, or in areas where you suspect underwater obstacles may exist which could be struck by the outboard or the boat bottom. **The most important thing you can do to help reduce injury or impact damage from striking a floating or underwater object is to control the boat speed. Under these conditions, boat speed should be kept to a minimum planing speed 24 to 40 km/h (15 to 25 MPH) .**

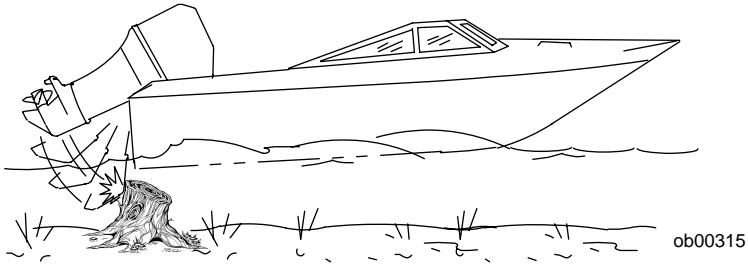

### **⚠ WARNING**

**To avoid serious injury or death from all or part of an outboard coming into the boat after striking a floating or underwater obstacle maintain a top speed no greater than minimum planing speed.**

Striking a floating or underwater object could result in an infinite number of situations. Some of these situations could result in the following:

- Part of the outboard or the entire outboard could break loose and fly into the boat.
- The boat could move suddenly in a new direction. Such a sharp change in direction can cause occupants to be thrown out of their seats or out of the boat.
- A rapid reduction in speed. This will cause occupants to be thrown forward, or even out of the boat.
- Impact damage to the outboard and/or boat.

# GENERAL INFORMATION

Keep in mind, the most important thing you can do to help reduce injury or impact damage during an impact is control the boat speed. Boat speed should be kept to a minimum planing speed when driving in waters known to have underwater obstacles.

After striking a submerged object, stop the engine as soon as possible and inspect it for any broken or loose parts. If damage is present or suspected, the outboard should be taken to an authorized dealer for a thorough inspection and necessary repair.

The boat should also be checked for any hull fractures, transom fractures, or water leaks.

Operating a damaged outboard could cause additional damage to other parts of the outboard, or could affect control of the boat. If continued running is necessary, do so at greatly reduced speeds.

## **WARNING**

**Avoid serious injury or death from loss of boat control. Continued boating with major impact damage can result in sudden outboard component failure with or without subsequent impacts. Have the outboard thoroughly inspected and any necessary repairs made.**

## Exhaust Emissions

### BE ALERT TO CARBON MONOXIDE POISONING

Carbon monoxide is present in the exhaust fumes of all internal combustion engines. This includes the outboards, sterndrives and inboard engines that propel boats, as well as the generators that power various boat accessories. Carbon monoxide is a deadly gas that is odorless, colorless and tasteless.

Early symptoms of carbon monoxide poisoning which should not be confused with seasickness or intoxication, include headache, dizziness, drowsiness, and nausea.

## **WARNING**

**Avoid the combination of a running engine and poor ventilation. Prolonged exposure to carbon monoxide in sufficient concentration can lead to unconsciousness, brain damage, or death.**

# GENERAL INFORMATION

## GOOD VENTILATION

Ventilate passenger area, open side curtains, or forward hatches to remove fumes.

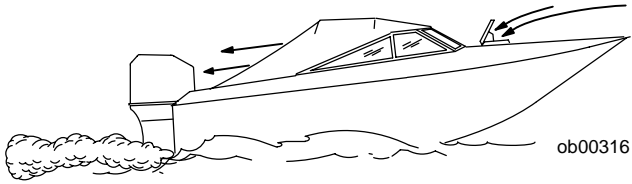

Example of desired air flow through the boat.

## POOR VENTILATION

Under certain running and/or wind conditions, permanently enclosed or canvas enclosed cabins or cockpits with insufficient ventilation may draw in carbon monoxide. Install one or more carbon monoxide detectors in your boat.

Although the occurrence is rare, on a very calm day, swimmers and passengers in an enclosed area of a stationary boat that contains or is near a running engine may be exposed to a hazardous level of carbon monoxide.

## WHILE BOAT IS STATIONARY

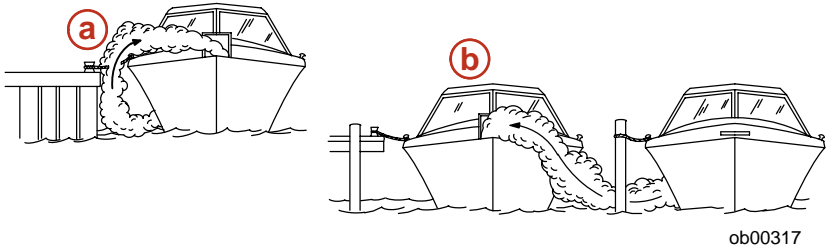

- a** - Running the engine when the boat is moored in a confined space.
- b** - Mooring close to another boat that has its engine running.



# GENERAL INFORMATION

## WHILE BOAT IS MOVING

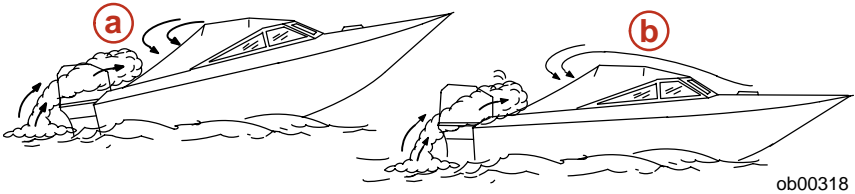

- a - Running the boat with the trim angle of the bow too high.
- b - Running the boat with no forward hatches open.

## Selecting Accessories For Your Outboard

Genuine Mercury Precision or Quicksilver Accessories have been specifically designed and tested for your outboard. These accessories are available from Mercury Marine dealers.

### **⚠ WARNING**

**Check with your dealer before installation of accessories. The misuse of acceptable accessories or the use of unacceptable accessories can result in serious injury, death, or product failure.**

Some accessories not manufactured or sold by Mercury Marine are not designed to be safely used with your outboard or outboard operating system. Acquire and read the installation, operation, and maintenance manuals for all your selected accessories.

## Safe Boating Suggestions

In order to safely enjoy the waterways, familiarize yourself with local and other governmental boating regulations and restrictions, and consider the following suggestions.

**Use flotation devices.** Have an approved personal flotation device of suitable size for each person aboard (it is the law) and have it readily accessible.

**Do not overload your boat.** Most boats are rated and certified for maximum load (weight) capacities (refer to your boat capacity plate). If in doubt, contact your dealer or the boats manufacturer.

**Perform safety checks and required maintenance.** Follow a regular schedule and ensure that all repairs are properly made.

# GENERAL INFORMATION

**Know and obey all nautical rules and laws of the waterways.** Boat operators should complete a boating safety course. Courses are offered in the U.S.A. by 1) The U.S. Coast Guard Auxiliary, 2) The Power Squadron, 3) The Red Cross and 4) your state boating law enforcement agency. Inquiries may be made to the Boating Hotline, 1-800-368-5647 or the Boat U.S. Foundation information number 1-800-336-BOAT.

**Make sure everyone in the boat is properly seated.** Do not allow anyone to sit or ride on any part of the boat that was not intended for such use. This includes the back of seats, gunwales, transom, bow, decks, raised fishing seats, any rotating fishing seat; or anywhere that an unexpected acceleration, sudden stopping, unexpected loss of boat control, or sudden boat movement could cause a person to be thrown overboard or into the boat.

**Never be under the influence of alcohol or drugs while boating (it is the law).** Alcohol or drug use impairs your judgment and greatly reduces your ability to react quickly.

**Prepare other boat operators.** Instruct at least one other person on board in the basics of starting and operating the outboard, and boat handling, in case the driver becomes disabled or falls overboard.

**Passenger boarding.** Stop the engine whenever passengers are boarding, unloading, or are near the back (stern) of the boat. Just shifting the outboard into neutral is not sufficient.

**Be alert.** The operator of the boat is responsible by law to maintain a proper lookout by sight and hearing. The operator must have an unobstructed view particularly to the front. No passengers, load, or fishing seats should block the operators view when operating the boat above idle speed.

**Never drive your boat directly behind a water skier in case the skier falls.** As an example, your boat traveling at 40 km/h (25 MPH) will overtake a fallen skier 61 m (200 ft.) in front of you in 5 seconds.

**Watch fallen skiers.** When using your boat for water skiing or similar activities, always keep a fallen or down skier on the operator's side of the boat while returning to assist the skier. The operator should always have the down skier in sight and never back up to the skier or anyone in the water.

# GENERAL INFORMATION

**Report accidents.** Boat operators are required by law to file a Boating Accident Report with their state boating law enforcement agency when their boat is involved in certain boating accidents. A boating accident must be reported if 1) there is loss of life or probable loss of life, 2) there is personal injury requiring medical treatment beyond first aid, 3) there is damage to boats or other property where the damage value exceeds \$500.00 or 4) there is complete loss of the boat. Seek further assistance from local law enforcement.

## Recording Serial Number

It is important to record this number for future reference. The serial number is located on the outboard as shown.

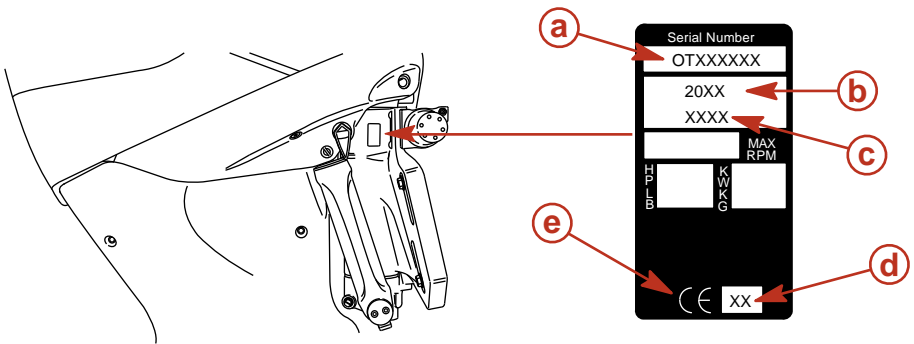

ob01322

- a** - Serial number
- b** - Model year
- c** - Model designation

- d** - Year manufactured
- e** - Certified Europe Insignia (as applicable)

## Specifications

Models	200/225/250/275
Horsepower	200/225/250/275
Kilowatts	149/168/186/205
Full Throttle RPM Range	5800-6400
Idle Speed in Neutral Gear <sup>1</sup> .	550 RPM
Number of Cylinders	6

<sup>1</sup>. With engine fully warmed up.

## GENERAL INFORMATION

<b>Models</b>	<b>200/225/250/275</b>
Piston Displacement	2,598 cc (158.5 cid)
Cylinder Bore	82 mm (3.23 in.)
Stroke	82 mm (3.23 in.)
Recommended Spark Plug	NGK ILFR6G
Spark Plug Gap	0.8 mm (0.0315 in.)
Spark Plug Hex Size	16 mm
Gear Ratio	1.85:1
Recommended Gasoline	Refer to <b>Fuel &amp; Oil</b>
Recommended Oil	Refer to <b>Fuel &amp; Oil</b>
Right Hand Rotation Gearcase Lubricant Capacity	970 ml (32.8 fl. oz.)
Left Hand Rotation Gearcase Lubricant Capacity	900 ml (30.4 fl. oz.)
Engine Oil Capacity With Oil Filter Replacement	7.0 liters (7.4 qt)
Battery Rating	1000 Marine Cranking Amps (MCA), 800 Cold Cranking AMPS (CCA) or 180 Ampere Hour (Ah)

# GENERAL INFORMATION

## Component Identification

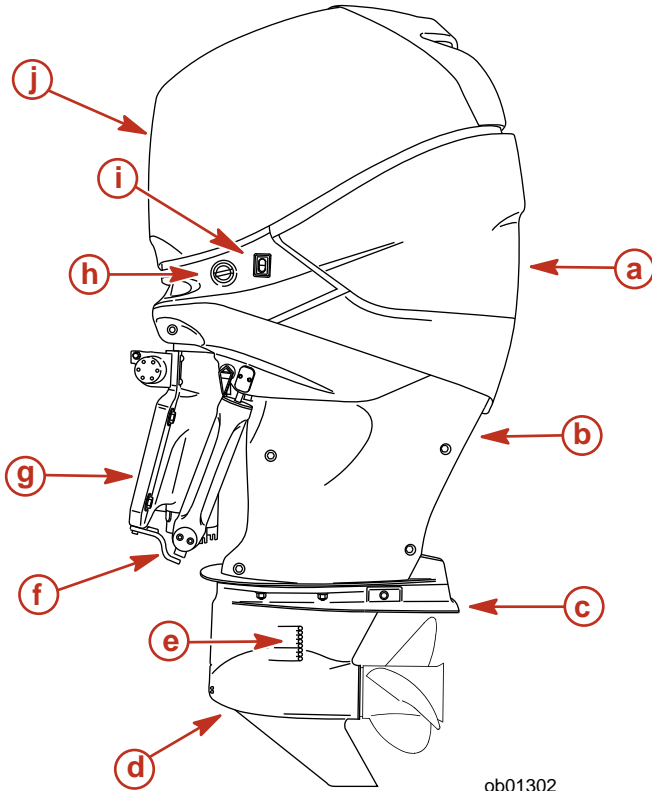

ob01302

- |                                       |                                  |
|---------------------------------------|----------------------------------|
| <b>a</b> - Rear cowl                  | <b>f</b> - Spray plate           |
| <b>b</b> - Lower cowl chaps           | <b>g</b> - Pedestal              |
| <b>c</b> - Anti-ventilation plate     | <b>h</b> - Engine flush          |
| <b>d</b> - Gearcase                   | <b>i</b> - Auxiliary tilt switch |
| <b>e</b> - Cooling water intake holes | <b>j</b> - Top cowl              |

# INSTALLATION

## Installing Outboard

### **⚠ WARNING**

Before operation, the outboard must be correctly installed with the required mounting hardware as shown. Failure to correctly fasten outboard could result in outboard ejecting off boat transom causing serious injury, death, or property damage.

**IMPORTANT:** For optimum boat performance and detailed engine installation instructions, refer to the outboard installation manual, supplied with the outboard.

We strongly recommend that your dealer install your outboard and related accessories to ensure proper installation and good performance. If you install the outboard yourself, follow instructions in the Outboard Installation Manual which is provided with the outboard.

The outboard must be secured to the boat transom with the four 12.7 mm (1/2 in.) diameter mounting bolts, locknuts and washers provided. Install two bolts through the upper set of mounting holes and two bolts through the lower set of mounting slots.

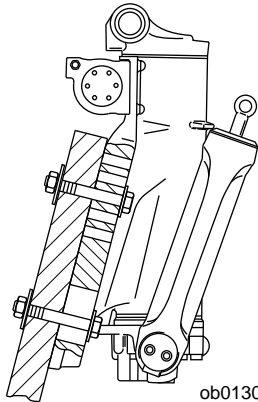

# INSTALLATION

## MAXIMUM OUTBOARD MOUNTING HEIGHT

The mounting height of the outboard must not exceed 63.5 cm (25 in.) for L models, 76.2 cm (30 in.) for XL models and 88.9 cm (35 in.) for XXL models. Mounting the outboard higher may cause damage to the gearcase components.

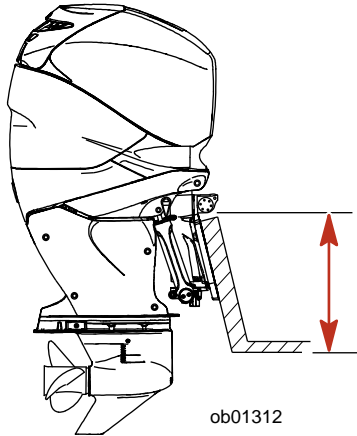

## Maximum Static Waterline

The static waterline, with boat at rest, must be below the "MAX STATIC WATERLINE" mark on the idle relief grommet (located at the rear of the outboard) when the outboard is fully tilted in/down. If waterline is above "MAX STATIC WATERLINE" mark, adjust boat load forward or increase (raise) outboard mounting height to correctly place mark above waterline.

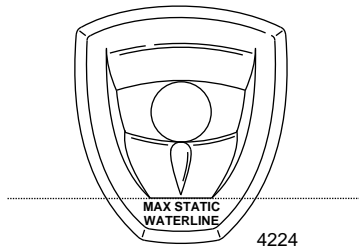

# INSTALLATION

## Propeller Selection

For best all around performance from your outboard/boat combination, select a propeller that allows the engine to operate in the upper half of the recommended full throttle RPM range with the boat normally loaded (refer to **General Information - Specifications**). This RPM range allows for better acceleration while maintaining maximum boat speed.

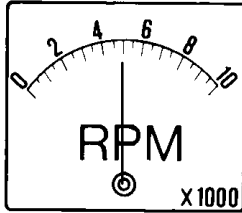

ob00323

If changing conditions cause the RPM to drop below the recommended range, such as warmer, more humid weather, operation at higher elevations, increased boat load, or a dirty boat bottom/gearcase, a propeller change or cleaning may be required to maintain performance and ensure the outboards durability.

Check full-throttle RPM, using an accurate tachometer, with the engine trimmed out to a balanced-steering condition (steering effort equal in both directions) without causing the propeller to break loose.



# TRANSPORTING

## Trailing Boat/Outboard

When transporting the boat on a trailer, the outboard should be positioned and/or supported in one of the following ways:

1. If the boat trailer provides sufficient ground clearance, the outboard may be tilted down to the vertical operating position with no additional support required.

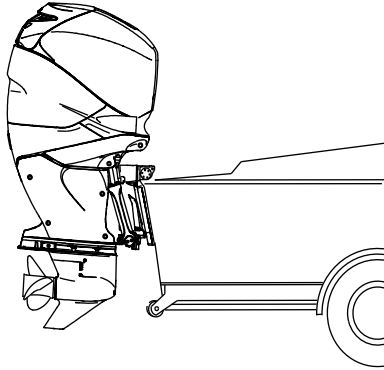

ob01268

2. If additional ground clearance is required, the outboard should be tilted up and supported using the outboard's tilt support bracket (trailing position) and/or an accessory transom support device. Refer to **Features and Controls - Tilting Operation**.

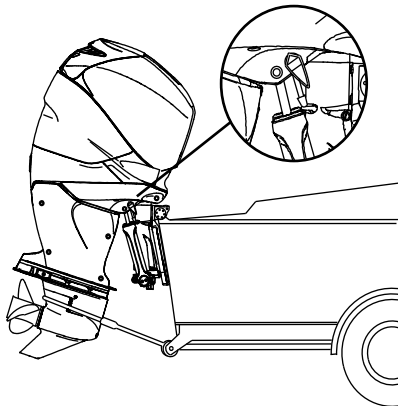

ob01307

# TRANSPORTING

3. For maximum ground clearance, the outboard can be tilted to the full tilt position and supported using the outboards tilt support bracket and/or an accessory transom support device.

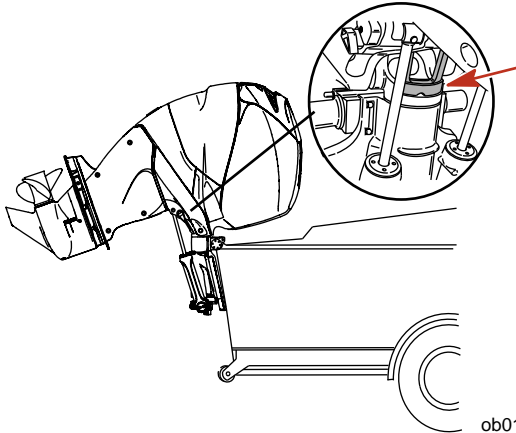

Additional clearance may be required for railroad crossings, driveways and trailer bouncing. Refer to your local dealer for recommendations.

**IMPORTANT: Do not rely on the power trim/tilt system to maintain proper ground clearance for trailering. The power trim/tilt system is not intended to support the outboard for trailering.**

Shift the outboard to forward gear. This prevents the propeller from spinning freely when boat is trailered.

# FUEL AND OIL

## Gasoline Recommendations

### UNITED STATES AND CANADA

**Model 275** The use of a major brand of automotive unleaded gasoline with a minimum posted octane rating of 91 is required for best performance. Use of a major brand of automotive unleaded gasoline with a minimum pump posted octane rating of 87 is acceptable, however performance losses may occur. Automotive gasolines that contain fuel injector cleaners are preferred for added internal engine cleanliness. Leaded gasoline is not recommended.

**Models 200/225/250** Use a major brand of automotive unleaded gasoline with a minimum pump posted octane rating of 87. Automotive gasolines that contain fuel injector cleaners are preferred for added internal engine cleanliness. Leaded gasoline is not recommended.

### USING REFORMULATED (OXYGENATED) FUELS - UNITED STATES ONLY

This type of fuel is required in certain areas of the United States. The two types of reformulated ingredients in these fuels are alcohol (Ethanol) or Ether (MTBE or ETBE). If Ethanol is the oxygenate that is used in the gasoline, refer to **Alcohol in Gasoline**.

These reformulated fuels are acceptable for use in the Mercury engine.

### INTERNATIONAL

**Model 275** The use of a major brand of automotive unleaded gasoline with a minimum posted octane rating of 96 RON is required for best performance. Use of a major brand of automotive unleaded gasoline with a minimum pump posted octane rating of 90 RON is acceptable, however performance losses may occur. Automotive gasolines that contain fuel injector cleaners are preferred for added internal engine cleanliness. Leaded gasoline is acceptable in areas where unleaded gasoline is not available.

**Models 200/225/250** Use a major brand of automotive unleaded gasoline with a minimum pump posted octane rating of 90 RON. Automotive gasolines that contain fuel injector cleaners are preferred for added internal engine cleanliness. Leaded gasoline is acceptable in areas where unleaded gasoline is not available.

### ALCOHOL IN GASOLINE

We do not recommend the use of gasoline which contains alcohol because of the possible adverse effect the alcohol may have on the fuel system. In general, if only gasoline containing alcohol is available, it must not contain more than 10% ethanol or 5% methanol, and the addition of an accessory water separating fuel filter is recommended.

# FUEL AND OIL

If gasoline containing alcohol is used or if you suspect the presence of alcohol in your gasoline, increase your inspection of the fuel system, visually checking for fuel leaks or abnormalities.

Gasoline containing alcohol may cause the following problems to your outboard and fuel system:

- Corrosion of metal parts
- Deterioration of elastomers and plastic parts
- Wear and damage of internal engine parts
- Starting and operating difficulties
- Vapor lock or fuel starvation

Some of these adverse effects are due to the tendency of gasoline containing alcohol to absorb moisture from the air, resulting in a phase of water and alcohol which separates from the gasoline in the fuel tank.

The adverse effects of alcohol are more severe with methanol and are worse with increasing content of alcohol.

## Filling Fuel Tank

### **WARNING**

**Avoid serious injury or death from a gasoline fire or explosion. Always stop the engine and do not smoke or allow open flames or sparks in the area while filling fuel tanks.**

Fill fuel tanks outdoors away from heat, sparks, and open flames.

Remove portable fuel tanks from boat to refill them.

Always stop engine before refilling tanks.

Do not completely fill the fuel tanks. Leave approximately 10% of the tank volume unfilled. Fuel will expand in volume as its temperature rises and can leak under pressure if the tank is completely filled.

## **PORTABLE FUEL TANK PLACEMENT IN THE BOAT**

Place the fuel tank in the boat so the vent is higher than the fuel level under normal boat operating conditions.

## **Engine Oil Recommendations**

Mercury or Quicksilver NMMA FC-W certified synthetic blend 25W-40 multi-viscosity 4-Stroke Outboard Oil is recommended for general, all-temperature use. If the recommended Mercury or Quicksilver NMMA FC-W certified oil is not available, a major brand of NMMA FC-W certified 4-Stroke Outboard Oil of similar viscosity may be used.

# FUEL AND OIL

**IMPORTANT:** The use of non-detergent oils, multi-viscosity oils (other than Mercury or Quicksilver NMMA FC-W certified oil or a major brand NMMA FC-W certified oil), synthetic oils, low quality oils or oils that contain solid additives are not recommended.

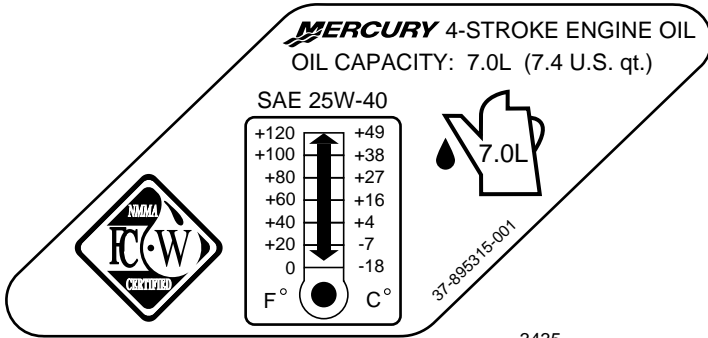

## Checking And Adding Engine Oil

**IMPORTANT:** Do not overfill. Tilt outboard out/up past vertical for approximately one minute to allow trapped oil to drain back to the oil sump. Tilt outboard to vertical (not tilted) position when checking engine oil. For accurate readings, check oil only when engine is cold or after engine has not run for at least an hour.

1. Before starting (cold engine) tilt outboard out/up past vertical to allow trapped oil to drain back to the oil sump. Allow outboard to remain tilted for approximately one minute.
2. Tilt outboard to vertical operating position.
3. Remove the top cowl. Refer to **Maintenance - Cowl Removal And Installation**.
4. Pull out the dipstick. Wipe the dipstick end with a clean rag or towel and push it back in all the way.
5. Pull the dipstick back out again and observe the oil level. Oil should be in the operating range (cross hatched region).

# FUEL AND OIL

**IMPORTANT:** Do not try to fill the oil level to the top of the operating range (cross hatched region). Oil level is correct as long as it appears in the operating range (cross hatched region).

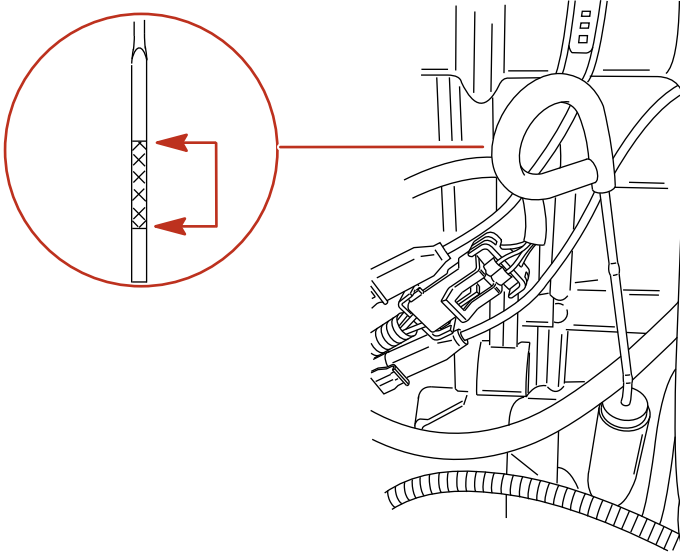

ob01255

6. If the oil level is below the operating range (cross hatched region), remove the oil filler cap and add approximately 500 ml (16 oz.) of specified outboard motor oil. Allow a few minutes for the added oil to drain to the oil sump and recheck the dipstick. Repeat the process until oil level is on the operating range (cross hatched region). Do not try to fill to the upper end of the operation range (cross hatched region).

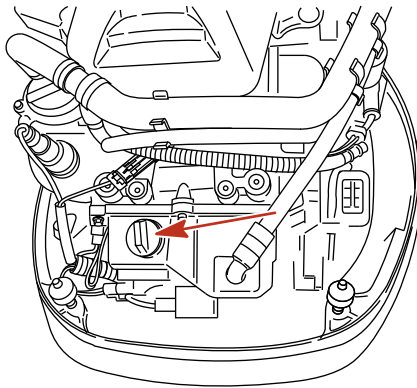

ob01250

## FUEL AND OIL

**IMPORTANT:** Inspect oil for signs of contamination. Oil contaminated with water will have a milky color to it; oil contaminated with fuel will have a strong fuel smell. If contaminated oil is noticed, have the engine checked by your dealer.

7. Push the dipstick back in all the way.
8. Reinstall the oil fill cap hand tight.
9. Reinstall top cowl.

# FEATURES AND CONTROLS

## Remote Control Features

### PANEL MOUNT FEATURES

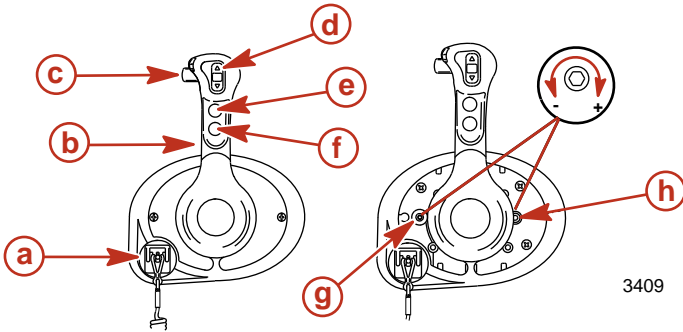

- a** - Lanyard/lanyard stop switch - Refer to **General Information - Lanyard Stop Switch**.
- b** - Control handle – Forward (F), Neutral (N), Reverse (R).
- c** - Shift lock - Refer to **Operation - Gear Shifting**.
- d** - Trim/tilt switch - Refer to **Power Trim and Tilt**.
- e** - Throttle only button - Allows the boat operator to increase engine RPM for warm-up, without shifting the engine into gear.
- f** - Stop/start button - Allows the boat operator to start or stop the engine without using the ignition key.
- g** - Detent tension adjustment - Refer to **Operation - Remote Control Adjustments**.
- h** - Control handle friction adjustment screw - Refer to **Operation - Remote Control Adjustments**.



# FEATURES AND CONTROLS

## CONSOLE MOUNT FEATURES - SINGLE ENGINE

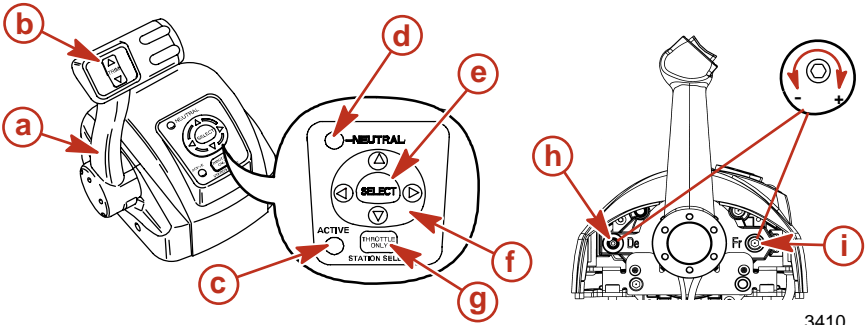

3410

- a** - Control handle - Forward (F), Neutral (N), Reverse (R).
- b** - Trim/tilt switch - Refer to **Power Trim and Tilt**.
- c** - Active light - Illuminated when remote control is active and ready.
- d** - Neutral light - Illuminated when engine is in neutral gear position. Blinks when engine is in throttle only mode.
- e** - Select key - Used to select System View on-screen options, if equipped. Refer to **System View Operation Manual** for screen options.
- f** - Arrow trackpad - Used to scroll through System View displays, if equipped. Refer to **System View Operation Manual** for screen options.
- g** - Throttle only/station select key - Allows the boat operator to increase engine RPM for warm-up, without shifting the engine into gear. Allows the boat operator to select which station will be used for dual helm applications. Refer to **Operation - Starting The Engine**.
- h** - Detent tension adjustment - Refer to **Operation - Remote Control Adjustments**.
- i** - Control handle friction adjustment screw - Refer to **Operation - Remote Control Adjustments**.

# FEATURES AND CONTROLS

## CONSOLE MOUNT FEATURES - DUAL ENGINE

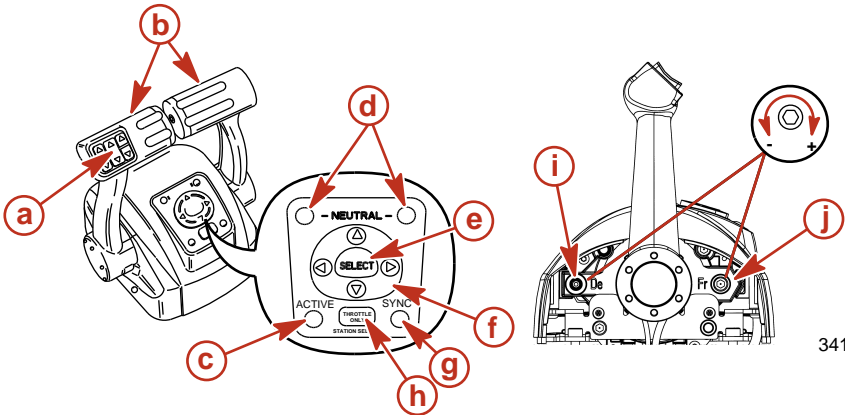

3411

- a** - Trim/tilt switch - Refer to **Power Trim and Tilt**.
- b** - Control handles - Forward (F), Neutral (N), Reverse (R).
- c** - Active light - Illuminated when remote control is active and ready to use.
- d** - Neutral light - Illuminated when engine is in neutral gear position. Blinks when engine is in throttle only mode.
- e** - Select key - Used to select System View on-screen options, if equipped. Refer to **System View Operation Manual** for screen options.
- f** - Arrow trackpad - Used to scroll through System View displays, if equipped. Refer to **System View Operation Manual** for screen options.
- g** - Sync light - Illuminated when the auto synchronizing feature is engaged. Refer to **Operation - Starting The Engine**.
- h** - Throttle only/station select key - Allows the boat operator to increase engine RPM for warm-up, without shifting the engine into gear. Allows the boat operator to select which station will be used for dual helm applications. Refer to **Operation - Starting The Engine**.
- i** - Detent tension adjustment - Refer to **Operation - Remote Control Adjustments**.
- j** - Control handle friction adjustment screw - Refer to **Operation - Remote Control Adjustments**.

# FEATURES AND CONTROLS

## Warning System

### WARNING HORN SIGNALS

When the key switch is turned to the "ON" position, the horn (located on the command module harness) will turn on for a moment as a test to indicate the horn is working.

The warning horn will emit either a continuous beep or intermittent short beeps. This will alert the operator and help identify the following listed situations. For visual display of the specific engine functions and for additional engine data, refer to **SmartCraft Product** information, following.

Warning Horn		
Function	Sound	Description
Start up	Single beep	Normal system test
Water in Fuel	Four beeps every 2 minutes	Water in engine mounted fuel filter. Refer to <b>Maintenance - Water Separating Fuel Filter</b> .
Low battery	Four beeps every 2 minutes	Battery charging unable to keep up with demand. Raise engine speed, to increase charge, or shut down accessories, to reduce demand.

# FEATURES AND CONTROLS

Warning Horn		
Function	Sound	Description
Cooling system problem	Continuous	Engine Guardian System is activated. Power limit will vary with level of overheat. Shift outboard into neutral and check for a steady stream of water coming out of the water pump indicator hole. If no water is coming out of the water pump indicator hole or flow is intermittent, stop engine and check water intake holes for obstruction.
Oil pressure low	Continuous	Engine Guardian System is activated. Power limit will vary depending on available oil pressure. Stop engine and check oil dipstick. Add oil if necessary. Refer to <b>Fuel and Oil - Checking and Adding Engine Oil.</b>

## FEATURES AND CONTROLS

Warning Horn		
Function	Sound	Description
Engine Overspeed	Continuous	The warning horn is activated any time the engine speed exceeds the maximum allowable RPM. The system will limit the engine speed to within the allowable range. Engine overspeed indicates a condition that should be corrected. Over speed could be caused by incorrect propeller pitch, engine height, trim angle, tilt angle (shallow water operation) etc.
Engine Communication/ Remote control failure	Intermittent beep	Engine Guardian System is activated. Power limit will restrict engine speed to idle.
Sensor/Actuator out of range	Single beep (engine running)	May be a problem with one of the engine functions. Have your dealer check the engine soon.
	Continuous	Engine Guardian System is activated. Power limit will restrict engine speed to either idle or 75%, depending on fault.

# FEATURES AND CONTROLS

## ENGINE GUARDIAN SYSTEM

The Engine Guardian System monitors the critical sensors on the engine for any early indications of problems. The system will respond to a problem by emitting a continuous beep and/or reducing engine power in order to provide engine protection.

If Guardian System has been activated, reduce throttle speed. The problem will need to be identified and corrected, if possible. The system must be reset before the engine will operate at higher speeds. Moving the throttle lever back to the idle position will reset the system.

## SMARTCRAFT PRODUCT

A Mercury SmartCraft System instrument package can be purchased for this outboard. A few of the functions the instrument package will display are engine RPM, coolant temperature, oil pressure, water pressure, battery voltage, fuel consumption and engine operating hours.

The SmartCraft Instrument package will also aid in Engine Guardian diagnostics. The SmartCraft Instrument package will display critical engine alarm data and potential problems.

# FEATURES AND CONTROLS

## Power Trim and Tilt

The outboard has a trim/tilt control called power trim. This enables the operator to easily adjust the position of the outboard by pressing the trim switch. Moving the outboard in closer to the boat transom is called trimming in or trimming down. Moving the outboard further away from the boat transom is called trimming out or trimming up. The term trim generally refers to the adjustment of the outboard within the first 20° range of travel. This is the range used while operating the boat on plane. The term tilt is generally used when referring to adjusting the outboard further up out of the water. With the engine not running and the key switch in the "ON" position, the outboard can be tilted out of the water. At low idle speed (2000 RPM and below), the outboard can also be tilted up past the trim range to permit shallow water operation.

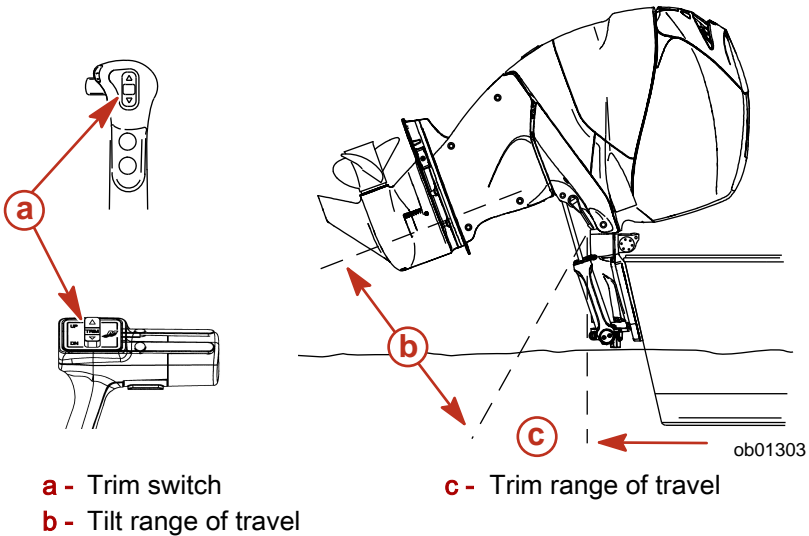

## POWER TRIM OPERATION

With most boats, operating around the middle of the trim range will give satisfactory results. However, to take full advantage of the trimming capability there may be times when you choose to trim the outboard all the way in or out. Along with an improvement in some performance aspects comes a greater responsibility for the operator, this being an awareness of some potential control hazards.

Consider the following lists carefully:

1. Trimming In or Down Can:
  - Lower the bow.

# FEATURES AND CONTROLS

- Result in quicker planing off, especially with a heavy load or a stern heavy boat.
- Generally improve the ride in choppy water.
- In excess can lower the bow of some boats to a point where they begin to plow with their bow in the water while on plane. This can result in an unexpected turn in either direction (called bow steering or over-steering) if any turn is attempted, or if a significant wave is encountered.

## WARNING

**Avoid possible serious injury or death. Adjust outboard to an intermediate trim position as soon as boat is on plane to avoid possible ejection due to boat spin out. Do not attempt to turn boat when on plane if outboard is trimmed extremely in or down and there is a pull on the steering wheel.**

2. Trimming Out or Up can:
  - Lift the bow higher out of the water.
  - Generally increase top speed.
  - Increase clearance over submerged objects or a shallow bottom.
  - In excess can cause boat porpoising (bouncing) or propeller ventilation.
  - Cause engine overheating if any cooling water intake holes are above the water line.

## TILTING TO FULL UP POSITION

### Tilt At Helm

**IMPORTANT:** Turning key to the "START" position while the engine is running will result in engine shut down, while leaving the DTS system active. This will allow the use of the power trim/tilt from the remote control handle.

1. Shut off engine by:
  - a. Turning the key to the "START" position, then releasing it to the "ON" position.
  - b. Turning the key to "OFF" position and returning it to the "ON" position.



# FEATURES AND CONTROLS

2. Press the trim/tilt switch to the up position. The outboard will tilt up until the switch is released or it reaches its maximum tilt position.

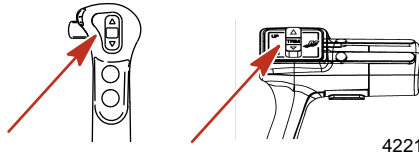

## Tilt At Engine

The cowl mounted auxiliary tilt switch can be used to tilt the outboard with the key switch in the "OFF" position.

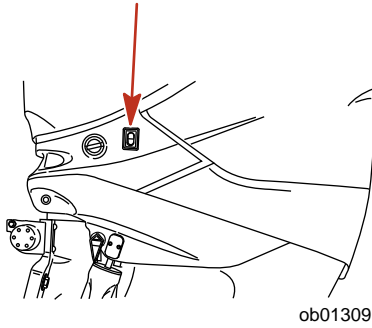

1. Rotate the tilt support lever down.
2. Lower outboard until tilt support bracket rests on the pedestal.
3. Disengage the tilt support bracket, by raising the outboard up and rotating the tilt support lever up. Lower the outboard.

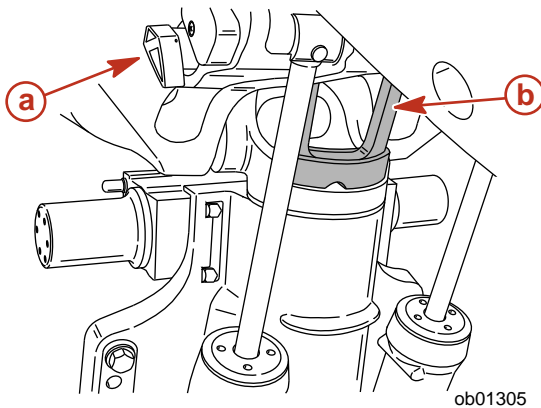

**a** - Tilt support lever

**b** - Tilt support bracket

# FEATURES AND CONTROLS

## MANUAL TILTING

If the outboard cannot be tilted using the power trim/tilt switch, the outboard can be manually tilted.

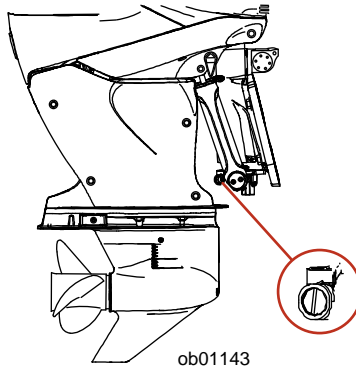

**NOTE:** The manual tilt release valve must be tightened before operating the outboard to prevent the outboard from tilting up during reverse operation.

1. Turn out the manual tilt release valve 3 turns counterclockwise. This allows manual tilting of the outboard. Tilt the outboard to the desired position and tighten the manual tilt release valve.

## AUXILIARY TILT SWITCH

The auxiliary tilt switch can be used to tilt the outboard up or down using the power trim system.

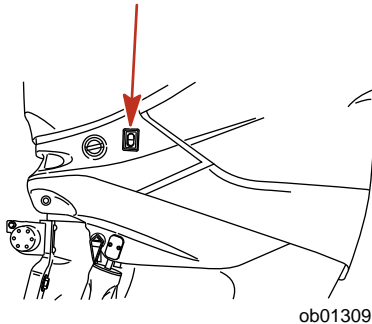

## SHALLOW WATER OPERATION

When operating your boat in shallow water, you can tilt the outboard beyond the maximum trim range to prevent hitting bottom.

1. Reduce engine speed below 2000 RPM.

## FEATURES AND CONTROLS

2. Tilt outboard up. Make sure all the water intake holes stay submerged at all times.
3. Operate the engine at slow speed only. With the outboard tilted past 20° trim limit, the warning horn will sound and engine speed will be automatically limited to approximately 2000 RPM. The outboard must be tilted (trimmed) down below the maximum trim range to allow operation above 2000 RPM.

# OPERATION

## Pre-Starting Check List

- Operator knows safe navigation, boating, and operating procedures.
- An approved personal flotation device of suitable size for each person aboard and readily accessible (it is the law).
- A ring type life buoy or buoyant cushion designed to be thrown to a person in the water.
- Know your boats maximum load capacity. Look at the boat capacity plate.
- Fuel supply OK.
- Arrange passengers and load in the boat so the weight is distributed evenly and everyone is seated in a proper seat.
- Tell someone where you are going and when you expect to return.
- It is illegal to operate a boat while under the influence of alcohol or drugs.
- Know the waters and area you will be boating; tides, currents, sand bars, rocks, and other hazards.
- Make inspection checks listed in **Maintenance - Inspection and Maintenance Schedule**.

## Operating In Freezing Temperatures

When using your outboard or having your outboard moored in freezing or near freezing temperatures, keep the outboard tilted down at all times so the gearcase is submerged. This prevents trapped water in gearcase from freezing and causing possible damage to the water pump and other components.

If there is a chance of ice forming on the water, the outboard should be removed and drained completely of water. If ice should form at the water level inside the outboard driveshaft housing, it will block water flow to the engine causing possible damage.

## Operating In Salt Water Or Polluted Water

We recommend that you flush the internal water passages of your outboard with fresh water after each use in salt or polluted water. This will prevent a buildup of deposits from clogging the water passages. Refer to **Maintenance - Flushing The Cooling System**.

If you keep your boat moored in the water, always tilt the outboard so the gearcase is completely out of water (except in freezing temperatures) when not in use.

# OPERATION

Wash the outboard exterior and flush out the exhaust outlet of the propeller and gearcase with fresh water after each use. Each month, spray Mercury Precision or Quicksilver Corrosion Guard on external metal surfaces. Do not spray on corrosion control anodes as this will reduce the effectiveness of the anodes.

## Engine Break-in Procedure

### ⚠ CAUTION

Severe damage to the engine can result by not complying with the Engine Break-in Procedure.

1. For the first two hours of operation, run the engine at varied throttle settings up to 4500 RPM or at three-quarter throttle, and at full throttle for approximately one minute every ten minutes.
2. For the next eight hours of operation, avoid continuous operation at full throttle for more than five minutes at a time.

## Starting The Engine

### PANEL MOUNT - SINGLE ENGINE STARTING PROCEDURE

Before starting, read the Pre-Starting Check List, Special Operating Instructions, and Engine Break-in Procedure in the Operation Section.

### ⚠ CAUTION

Never start or operate your outboard (even momentarily) without water circulating through all the cooling water intake holes in the gearcase to prevent damage to the water pump (running dry) or overheating of the engine.

1. Make sure the cooling water intake is submerged.

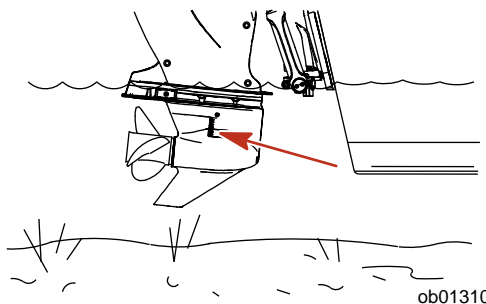

# OPERATION

2. Check the engine oil level.

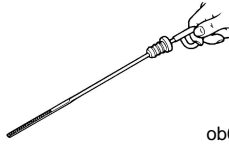

ob00667

3. Open fuel tank vent on manual venting type tanks.

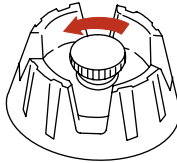

ob00348

**NOTE:** The engine will not start unless the lanyard is set to the "RUN" position.

4. Set the lanyard stop switch to the "RUN" position. Refer to **General Information - Lanyard Stop Switch**.



ob00350

5. Shift outboard to neutral (N) position.

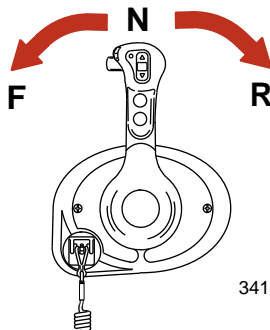

3413

**NOTE:** The engine can be started by using the ignition key or the start/stop button located on the remote control handle.

# OPERATION

6. Ignition key starting - Turn the ignition key to "START" position and release the key. The electronic starting system will automatically crank the engine for starting. If the engine fails to start, the engine will stop cranking. Turn the key to "START" position again until engine starts.

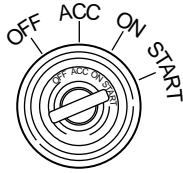

3485

7. Start/stop button - Turn the ignition key to "ON" position and press start/stop button and release. The electronic starting system will automatically crank the engine for starting. If the engine fails to start, the engine will stop cranking. Press start/stop button and release again until engine starts.

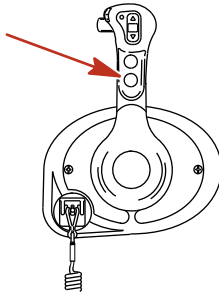

3414

## Warming up engine

Throttle Only Button - This feature allows the boat operator to increase engine RPM for warm-up, without shifting the engine into gear.

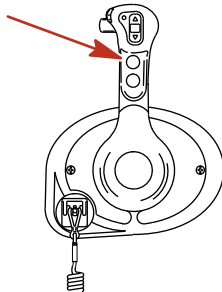

3416

1. Move the control handle into neutral position.
2. Depress shift lock button, press and hold the throttle only button while moving the control handle ahead to the forward detent. The horn sound indicates that throttle only is engaged.

# OPERATION

3. Advance the control handle to increase engine RPM. Engine RPM is limited to prevent engine damage.
4. To disengage, return the control handle back to neutral position.

## CONSOLE MOUNT - SINGLE ENGINE STARTING PROCEDURE

Before starting, read the Pre-Starting Check List, Special Operating Instructions, and Engine Break-in Procedure in the Operation Section.

### CAUTION

Never start or operate your outboard (even momentarily) without water circulating through all the cooling water intake holes in the gearcase to prevent damage to the water pump (running dry) or overheating of the engine.

1. Make sure the cooling water intake is submerged.

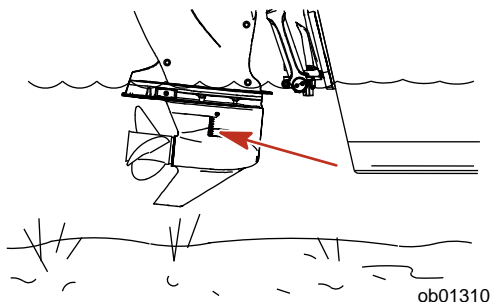

2. Check the engine oil level.

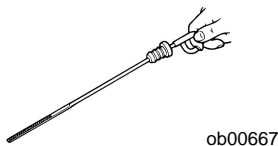

3. Open fuel tank vent on manual venting type tanks.

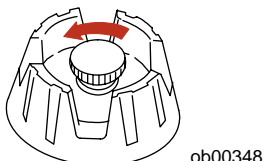

**NOTE:** The engine will not start unless the lanyard is set to the "RUN" position.



# OPERATION

- Set the lanyard stop switch to the "RUN" position. Refer to **General Information - Lanyard Stop Switch**.



ob00350

- Shift outboard to neutral (N) position.

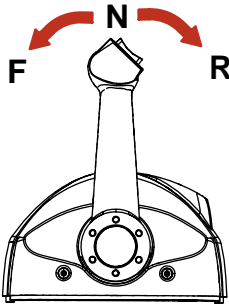

3417

- Turn the ignition key to "START" position and release the key. The electronic starting system will automatically crank the engine for starting. If the engine fails to start, the engine will stop cranking. Return the key to "START" position and try again.

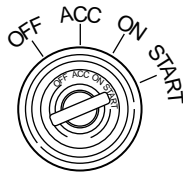

3485

# OPERATION

- The "ACTIVE" light located on the console remote control key pad will become illuminated once the engine is started and communicating with the remote control.

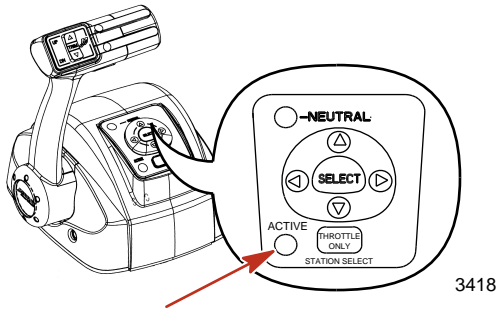

## Warming up engine

Throttle Only/Station Select Button - This feature allows the boat operator to increase engine RPM for warm-up, without shifting the engine into gear.

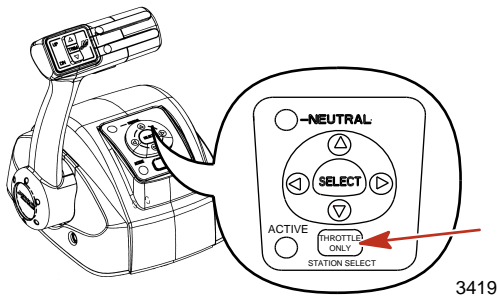

- Move the control handle into neutral position.
- Press and hold the throttle only/station select button while moving the control handle ahead to the forward detent.
- Hold in the button until the horn sounds twice and the neutral light starts flashing. The flashing light indicates that the throttle only is engaged.
- Advance the control handle to increase engine RPM. Engine RPM is limited to prevent engine damage.
- To disengage, return the control handle back to neutral position.

## CONSOLE MOUNT - DUAL ENGINE/DUAL HELM STARTING PROCEDURE

Before starting, read the Pre-Starting Check List, Special Operating Instructions, and Engine Break-in Procedure in the Operation Section.

# OPERATION

## ⚠ CAUTION

Never start or operate your outboard (even momentarily) without water circulating through all the cooling water intake holes in the gearcase to prevent damage to the water pump (running dry) or overheating of the engine.

1. Make sure the cooling water intake is submerged.

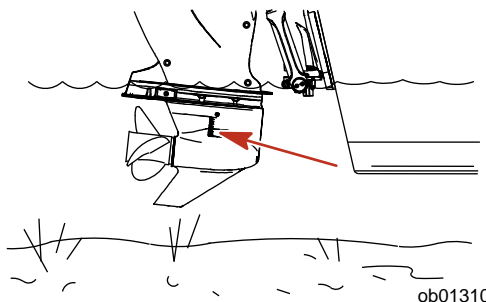

2. Check the engine oil level.

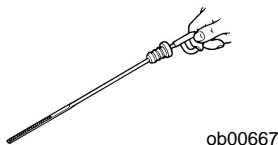

3. Open fuel tank vent on manual venting type tanks.

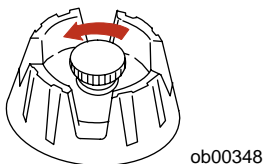

**NOTE:** The engine will not start unless the lanyard is set to the "RUN" position.

4. Set the lanyard stop switch to the "RUN" position. Refer to **General Information - Lanyard Stop Switch**.

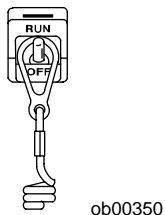

# OPERATION

5. Shift outboard to neutral (N) position.

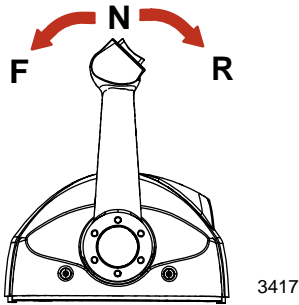

6. Turn the ignition key to "START" position and release the key. The electronic starting system will automatically crank the engine for starting. If the engine fails to start, the engine will stop cranking. Return the key to "START" position and try again. Repeat the procedure for the second engine.

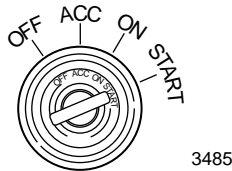

7. The "ACTIVE" light located on the console remote control key pad will become illuminated once the engine is started and communicating with the remote control.

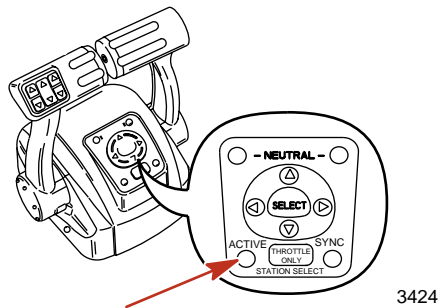

# OPERATION

## Warming up engine

Throttle Only/Station Select Button - This feature allows the boat operator to increase engine RPM for warm-up, without shifting the engines into gear.

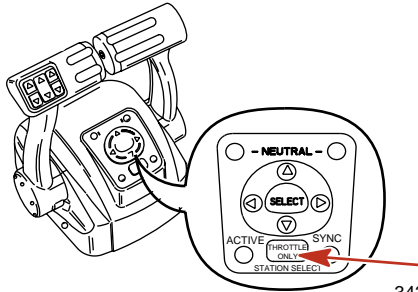

3425

1. Move the control handles into neutral position.
2. Press and hold the throttle only/station select button while moving the control handles ahead to the forward detent.
3. Hold in the button until the horn sounds twice and the neutral lights starts flashing. The flashing lights indicates that the throttle only is engaged.
4. Advance the control handles to increase engine RPM. Engine RPM is limited to prevent engine damage.
5. To disengage, return the control handles back to neutral position.
6. The warm up mode can be re-activated by turning off and re-starting the engine.

# OPERATION

## Gear Shifting

### DTS PANEL MOUNT REMOTE CONTROL

**IMPORTANT:** Never shift outboard into gear unless engine speed is at idle. Do not shift outboard into forward or reverse when the engine is not running.

- The outboard has three gear shift positions to provide operation. Forward (F), Neutral (N) and Reverse (R).

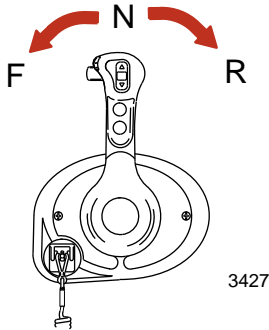

- When shifting, always stop at neutral position and allow the engine speed to return to idle.
- Panel mount remote control requires the operator to always press shift lock while moving the control handle out of the neutral position.

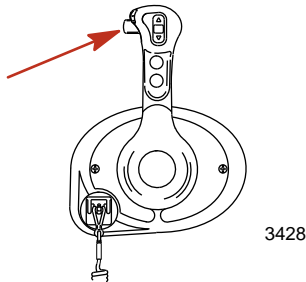

- Advance the control lever to further increase speed.

# OPERATION

## DTS CONSOLE MOUNT REMOTE CONTROL

**IMPORTANT:** Never shift outboard into gear unless engine speed is at idle. Do not shift outboard into forward or reverse when the engine is not running.

- The outboard has three gear shift positions to provide operation. Forward (F), Neutral (N) and Reverse (R).

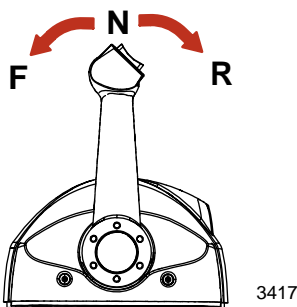

- When shifting, always stop at neutral position and allow the engine speed to return to idle.
- Advance the control lever to further increase speed.

## Dual Helm Station Transfer

The throttle only/station select button allows the boat operator to select which remote control is in control of the engine operation.

The active light is illuminated at the remote control station that is in control of the engine.

### WARNING

**Avoid serious injury or death from loss of boat control. The boat operator should never leave the active station while engine is in gear. Helm transfer should only be attempted while both stations are manned. One person helm transfer should only be performed while engine is in neutral.**

**NOTE:** Idle position is preferred when doing a station transfer. If conditions do not allow the remote control to be placed at idle position, a station transfer can be done while in gear.

**NOTE:** Pressing and releasing station select button at new station allows the engine control to be transferred to the new station. The control will automatically start adjusting engine RPM and gear position to match the control handle setting at the new station. Adjust control handles to the desired throttle and gear position.

1. Place active remote control lever to idle position.

# OPERATION

2. Proceed to the inactive helm station and position remote control lever to the idle position.
3. Press throttle only/station select button once. The "ACTIVE" light will illuminate to indicate the remote control station is in control of the engine.

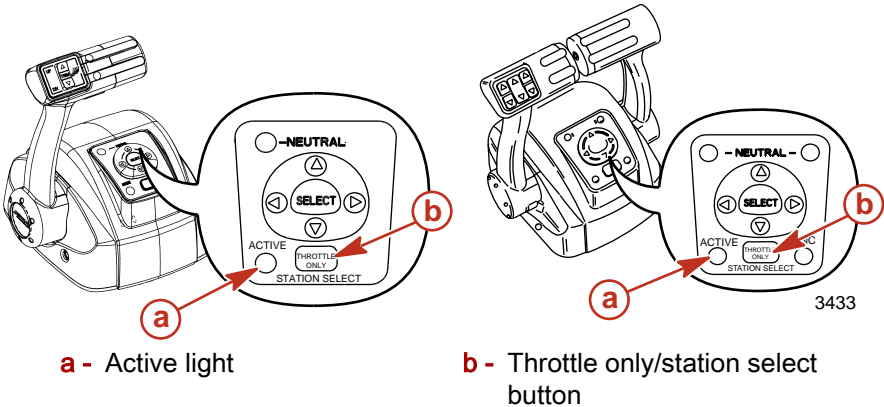

4. The active light will switch off at the original remote control station.

## SYNCHRONIZING DUAL HELMS PRIOR TO STATION TRANSFER

Pressing the station select button and holding it in allows the boat operator ten seconds to match up the control handle settings at the new station with the handle settings that are at the old (to be inactive) station. If the handles are not matched, the neutral light will flash. The light blinks faster as the handles are nearing match position. Once light stays on solid, the handles are matched and the button can be released. Transfer process is complete and the new station is now in control. If the button is held for over 10 seconds, the station transfer is cancelled.

## Synchronizing Dual Engines

The auto synchronizing feature, when engaged, will automatically adjust the port engine speed to match the speed of the starboard engine.

Synchronizing of engines will automatically engage when the speed of both engines are over 900 RPM for two seconds and remote control handles are positioned are within 5° of each other.



# OPERATION

Auto Synchronizing will stay engaged up to 95% throttle opening. The Sync light will turn on when the engines are synchronized.

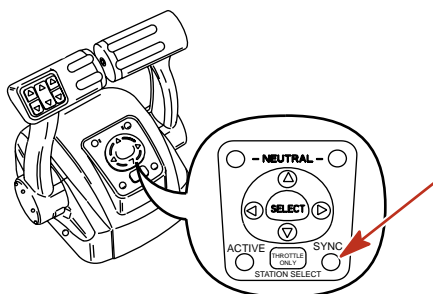

3434

To disengage, move one or both control handles until they are more than 5° apart, reduce engine speed below 900 RPM, or increase engine speed beyond 95%.

## Stopping The Engine

**IMPORTANT:** Turning key to the "START" position while the engine is running will result in engine shut down, while leaving the DTS system active. This will allow the use of the power trim/tilt from the remote control handle.

Reduce engine speed and shift outboard to neutral position. Turn ignition key to "OFF" position.

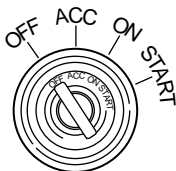

3482

# OPERATION

## Remote Control Adjustments

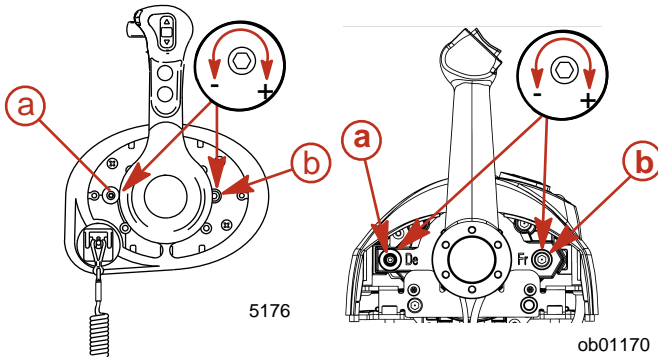

- a** - Detent tension adjustment
- b** - Control handle friction adjustment screw

1. Remove cover to gain access to screws.
2. **Detent tension adjustment** - The detent screw can be adjusted to increase or decrease the effort needed to move the control handle into or out of detent position.
3. **Control handle friction adjustment** - The friction adjustment screw can be adjusted to increase or decrease the overall effort to move the control handle. This will help prevent unwanted motion of the handle in rough water.
4. Turn screw towards "+" to increase friction or towards "-" to decrease friction.
5. Reinstall cover.

# MAINTENANCE

## Outboard Care

To keep your outboard in the best operating condition, it is important that your outboard receive the periodic inspections and maintenance listed in the Inspection and Maintenance Schedule. We urge you to keep it maintained properly to ensure the safety of you and your passengers, and retain its dependability.

### WARNING

**Neglected inspection and maintenance service of your outboard or attempting to perform maintenance or repair on your outboard if you are not familiar with the correct service and safety procedures could cause personal injury, death, or product failure.**

Record maintenance performed in Maintenance Log at the back of this book. Save all maintenance work orders and receipts.

## SELECTING REPLACEMENT PARTS FOR YOUR OUTBOARD

We recommend using original Mercury Precision or Quicksilver replacement parts and Genuine Lubricants.

### WARNING

**Using a replacement part that is inferior to the original part could result in personal injury, death, or product failure.**

## EPA Regulations

All new outboards manufactured by Mercury Marine are certified to the United States Environmental Protection Agency, as conforming to the requirements of the regulations for the control of air pollution from new outboard motors. This certification is contingent on certain adjustments being set to factory standards. For this reason, the factory procedure for servicing the product must be strictly followed and, wherever practicable, returned to the original intent of the design. **Maintenance, replacement, or repair of the emission control devices and systems may be performed by any marine spark ignition (SI) engine repair establishment or individual.**

# MAINTENANCE

## EPA Emissions

### EMISSION CERTIFICATION LABEL

An emission certification label, showing emission levels and engine specifications directly related to emissions, is placed on the engine at time of manufacture.

		EMISSION CONTROL INFORMATION	
THIS ENGINE CONFORMS TO <input type="checkbox"/> CALIFORNIA AND U.S. EPA EMISSION REGULATIONS FOR SPARK IGNITION MARINE ENGINES			
REFER TO OWNERS MANUAL FOR REQUIRED MAINTENANCE. SPECIFICATIONS AND ADJUSTMENTS			
<b>a</b>	IDLE SPEED (in gear): <input type="text"/>	FAMILY: <input type="text"/>	<b>f</b>
<b>b</b>	<input type="text"/> hp	<input type="text"/> cc	<b>g</b>
<b>c</b>	TIMING (IN DEGREES): <input type="text"/>		<b>h</b>
<b>d</b>	<input type="text"/>	SPARK PLUG: <input type="text"/>	<b>i</b>
<b>e</b>		GAP: <input type="text"/>	
	COLD VALVE CLEARANCE (mm): <input type="text"/>	INTAKE: <input type="text"/>	
		EXHAUST: <input type="text"/>	

ob00366

- |  |  |
|--|--|
| <b>a</b> - Idle speed                      | <b>f</b> - Family number                                 |
| <b>b</b> - Engine horsepower               | <b>g</b> - Maximum emission output for the engine family |
| <b>c</b> - Piston displacement             | <b>h</b> - Timing specification                          |
| <b>d</b> - Date of manufacture             | <b>i</b> - Recommended spark plug and gap                |
| <b>e</b> - Valve clearance (if applicable) |  |

## OWNER RESPONSIBILITY

The owner/operator is required to have routine engine maintenance performed to maintain emission levels within prescribed certification standards.

The owner/operator is not to modify the engine in any manner that would alter the horsepower or allow emissions levels to exceed their predetermined factory specifications.

## Inspection And Maintenance Schedule

### BEFORE EACH USE

- Check engine oil level. See **Fuel & Oil - Checking and Adding Engine Oil**.
- Check that lanyard stop switch stops the engine.
- Visually inspect the fuel system for deterioration or leaks.
- Check outboard for tightness on transom.

# MAINTENANCE

- Check steering system for binding or loose components.
- Visually check power steering fittings and hoses for leaks or signs of damage. Check tie bar fasteners (multiple outboard rigs) for proper tightness.
- Check propeller blades for damage.

## AFTER EACH USE

- Flush out the outboard cooling system if operating in salt or polluted water. See **Flushing the Cooling System**.
- Wash off all salt deposits and flush out the exhaust outlet of the propeller and gearcase with fresh water if operating in salt water.

## EVERY 100 HOURS OF USE OR ONCE YEARLY, WHICHEVER OCCURS FIRST

- Change engine oil and replace the oil filter. The oil should be changed more often when the engine is operated under adverse conditions such as extended trolling. See **Changing Engine Oil**.
- Inspect thermostat visually for corrosion and broken spring. Make sure thermostat closes completely at room temperature.<sup>1</sup>
- Check engine fuel filter for contaminants. See **Fuel System**.
- Check corrosion control anodes. Check more frequently when used in salt water. See **Corrosion Control Anodes**.
- Drain and replace gearcase lubricant. See **Gearcase Lubrication**.
- Check power steering fluid. See **Checking Power Steering Fluid**.
- Inspect battery. See **Battery Inspection**.
- Saltwater usage. Remove and inspect spark plugs for corrosion and replace spark plugs as necessary. Apply a thin coating of Anti-Seize Compound only on threads of spark plug prior to installation. See **Maintenance - Spark Plug Inspection and Replacement**.
- Check wiring and connectors
- Check tightness of bolts, nuts, and other fasteners.

## EVERY 300 HOURS OF USE OR THREE YEARS

**IMPORTANT:** Engine oil must be drained before removing gearcase to avoid oil spillage. Perform scheduled water pump replacement in combination with an engine oil change.

- Replace water pump impeller (more often if overheating occurs or reduced water pressure is noted).<sup>1</sup>
- Check power trim fluid. See **Checking Power Trim Fluid**.

<sup>1</sup> These items should be serviced by an authorized dealer.

# MAINTENANCE

- Replace spark plugs at first 300 hours or three years. After that, inspect spark plugs every 300 hours or three years. Replace spark plugs as needed. See **Spark Plug Inspection and Replacement**.
- Replace accessory drive belt. See **Accessory Drive Belt Inspection**.<sup>1</sup>

## BEFORE PERIODS OF STORAGE

- Refer to Storage procedure. See **Storage** section.

## Flushing The Cooling System

Flush the internal water passages of the outboard with fresh water after each use in salt, polluted, or muddy water. This will help prevent a buildup of deposits from clogging the internal water passages.

**NOTE:** *The outboard can be tilted or in the vertical operating position during flushing.*

1. With the engine turned off, place the outboard in either the operating position (vertical) or in a tilted position.
2. Disconnect the flush connector from fitting on the bottom cowl.

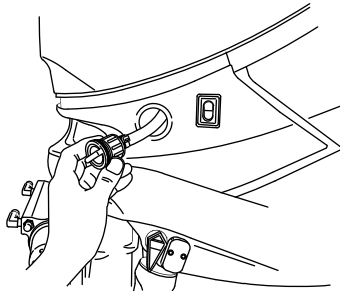

ob01236

3. Thread a water hose into the flush fitting.

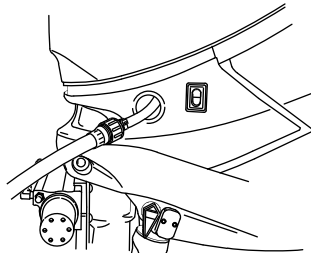

ob01237

4. Turn on the water tap (1/2 maximum) and let the water flush through the cooling system for about 15 minutes.
5. When flushing is complete, turn off water and disconnect the water hose.

# MAINTENANCE

6. Reinstall the flushing connector to the fitting on the bottom cowl. Tighten the connector securely.

## Cowl Removal and Installation

### COWL REMOVAL

**IMPORTANT:** Most maintenance points are accessible by removing the top cowl only.

1. Pull up on the top cowl lock latch.

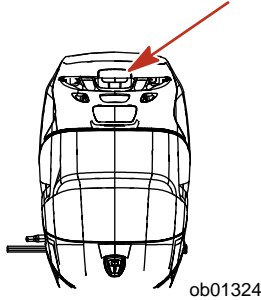

2. Pull top cowl forward and lift off.
3. Pull lower cowl release latch up.
4. Remove rear cowl towards aft of outboard.

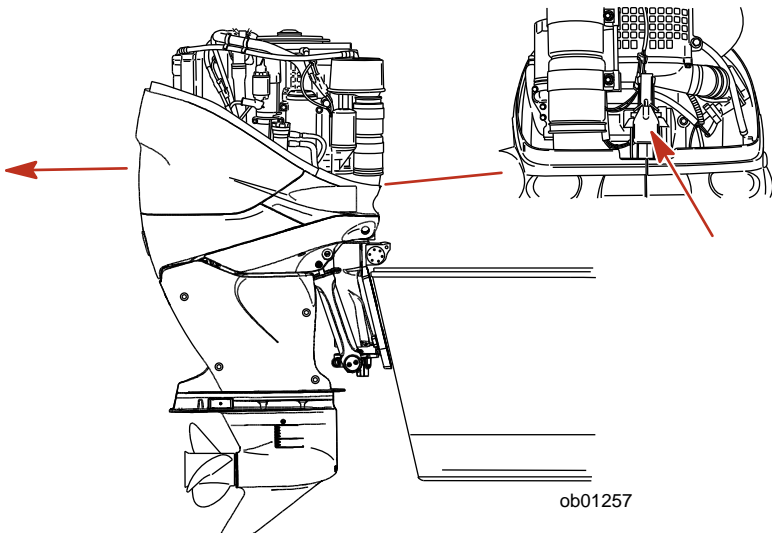

### COWL INSTALLATION

1. Position lower cowl from aft side of outboard. Make sure it fits properly in the rubber seal.

# MAINTENANCE

2. Lock cowl in place by pulling lower cowl latch down.

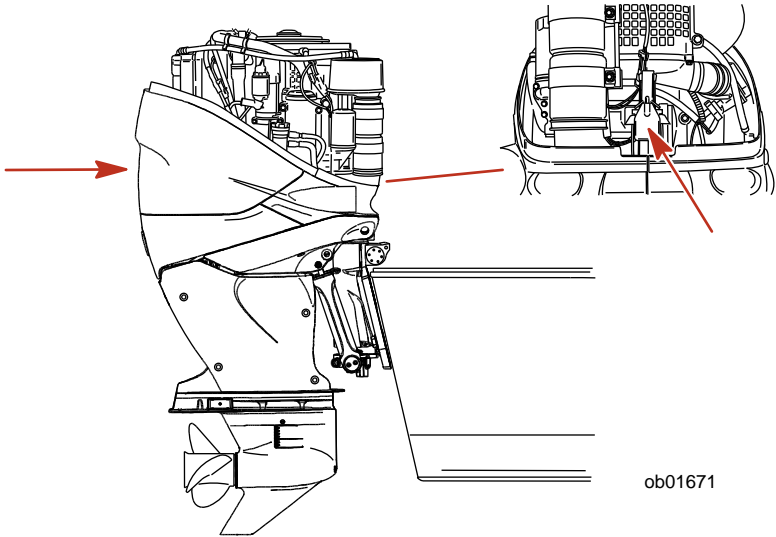

3. Place top cowl into position over engine, front first. Ensure cowl fits properly into the rubber seal.
4. The top cowl will lock into place when downward pressure is applied to the back side of cowl. Ensure cowl is securely fastened by pulling up on back of cowl.

## Exterior Care

The outboard is protected with a durable baked enamel finish. Clean and wax often using marine cleaners and waxes. Do not wax textured areas of cowl.

## Battery Inspection

The battery should be inspected at periodic intervals to ensure proper engine starting capability.

**IMPORTANT: Read the safety and maintenance instructions which accompany your battery.**

1. Turn off the engine before servicing the battery.
2. Add water as necessary to keep the battery full.
3. Make sure the battery is secure against movement.
4. Battery cable terminals should be clean, tight, and correctly installed. Positive to positive and negative to negative.
5. Make sure the battery is equipped with a nonconductive shield to prevent accidental shorting of battery terminals.



# MAINTENANCE

## DTS Battery Specifications

**IMPORTANT:** Do not use deep cycle batteries for the main engine starting battery.

**IMPORTANT:** Boating industry standards (BIA, ABYC, etc.), federal standards and Coast Guard regulations must be adhered to when installing the battery. Ensure that battery cable installation meets the pull test requirements and that positive battery terminal is properly insulated in accordance with regulations.

**IMPORTANT:** It is recommended (required in some states) that the battery be installed in an enclosed case. Refer to regulations for your area.

Minimum SAE Starting Battery Requirements - BCI GRP 24	
MCA	1000
CCA	800
Ah	180 (International Rating)

**NOTE:** Due to the wide variety of battery manufactures throughout the world, ratings and physical battery sizes will vary. Check with the manufacturer for a starting battery with a MCA, CCA, or Ah specification that will be equal to or greater than the SAE Standard J537 specified above.

**IMPORTANT:** For DTS products, each engine must be equipped with its own starting battery. If your boat application requires additional battery loads for boat accessories or marine electronics, it is recommended that an auxiliary battery or batteries be installed.

### CAUTION

Hex nuts must be used to secure battery leads to battery posts to avoid loss of electrical power.

When connecting engine battery, hex nuts must be used to secure battery leads to battery posts. Torque nuts to specifications.

Description	Nm	lb. in.	lb. ft.
Hex nuts	13.5	120	

**IMPORTANT:** Battery cable size and length is critical. Refer to Battery Cable Size tables or engine installation manual for size requirements.

# MAINTENANCE

Decal needs to be placed on or near battery box for future service reference. One 5/16 in. and one 3/8 in. hex nut are supplied per battery for wing nut replacement. Metric hex nuts are not supplied.

**NOTICE - DTS & Optimax Engines**

**DO NOT USE DEEP CYCLE BATTERIES!**  
DTS (Digital Throttle and Shift) applications and Optimax engines must use a marine starting battery with 1000 MCA, 800 CCA, or 180 Ah. rating.

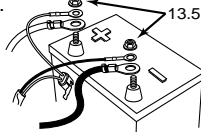

13.5Nm (120 lbs. in.)

**DO NOT USE WING NUTS.**

**IMPORTANT:**  
Battery cable size and length is critical. Refer to engine installation manual for size requirements.  
37-895387

Place decal on or near battery box for future service reference. 5/16" and 3/8" hex nuts supplied for wing nut replacement. Metric hex nuts not supplied.

3486

## Air Filter

The air filter assembly is a serviceable item and can be cleaned with warm soap water if required.

### AIR FILTER REMOVAL AND CLEANING

1. Loosen air filter clamp screw.
2. Remove crankcase ventilation hose.

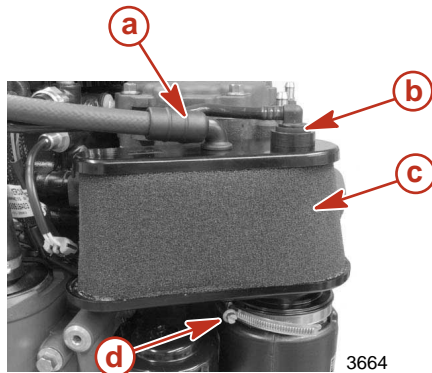

3664

- a** - Crankcase ventilation hose      **c** - Filter assembly  
**b** - Fuel System Module (FSM)      **d** - Clamp screw  
purge valve hose

# MAINTENANCE

3. Remove air filter assembly and disconnect Fuel System Module (FSM) purge valve hose by rotating the air filter assembly and pulling on hose.

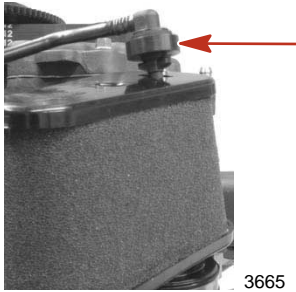

4. Wash air filter assembly in warm soap water.
5. Dry filter assembly with compressed air.
6. Apply 4-Cycle Outboard Oil on rag or towel and lightly pad air filter element. Wipe off excess oil. Air filter element should be moist to the touch.

## AIR FILTER INSTALLATION

1. Install Fuel System Module (FSM) purge valve hose to air filter assembly.

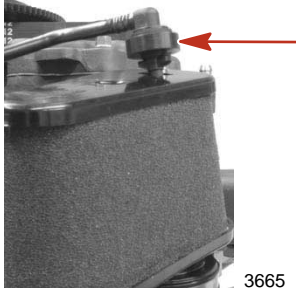

2. Install crancase ventilation hose.

# MAINTENANCE

3. Install air filter assembly and tighten clamp screw securely.

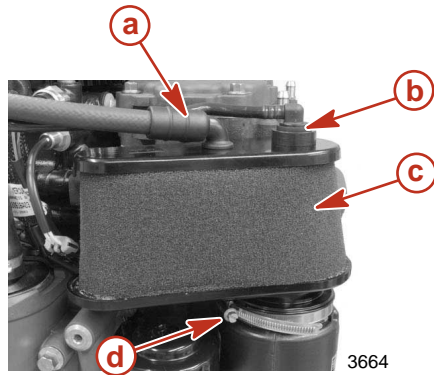

- a** - Crankcase ventilation hose      **c** - Filter assembly  
**b** - Fuel System Module (FSM) purge valve hose      **d** - Clamp screw

## Fuel System

### **⚠ WARNING**

Avoid serious injury or death from gasoline fire or explosion. Carefully follow all fuel system service instructions. Always stop the engine and do not smoke or allow open flames or sparks in the area while servicing any part of the fuel system.

**IMPORTANT:** Use an approved container to collect and store fuel. Wipe up spilled fuel immediately. Material used to contain spilled fuel must be disposed of in an approved receptacle.

Before servicing any part of the fuel system:

1. Stop engine and disconnect the battery.
2. Perform fuel system service in a well ventilated area.
3. Inspect any completed service work for sign of fuel leakage.

### FUEL LINE INSPECTION

Visually inspect the fuel line for cracks, swelling, leaks, hardness, or other signs of deterioration or damage. If any of these conditions are found, the fuel line must be replaced.

# MAINTENANCE

## WATER SEPARATING FUEL FILTER

**NOTE:** The warning system will turn on when water in the fuel filter reaches the full level. Refer to **Features and Controls - Warning System**.

This filter removes moisture and debris from the fuel. If the filter holder becomes filled with water, the water can be removed. If the filter becomes plugged with debris, replace the filter.

Refer to the **Inspection and Maintenance Schedule** for the proper maintenance interval.

### Filter Removal

1. Turn ignition key switch to "OFF" position.
2. Remove fuel vapor purge relief valve cap (green cap located aft of starter motor).

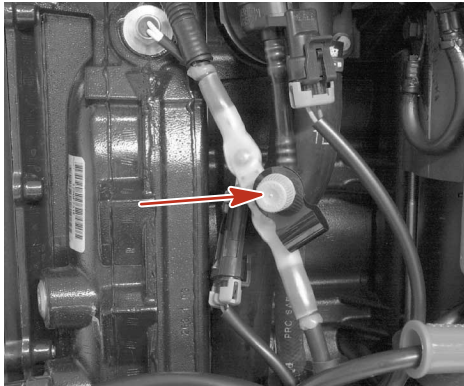

3470

### **⚠ CAUTION**

Fuel vapor vent system is under pressure. Cover valve assembly with a rag or towel to prevent fuel or fuel vapor spray. Relieve pressure slowly.

# MAINTENANCE

3. Place rag or towel around valve, release pressure by pushing core of valve end in.

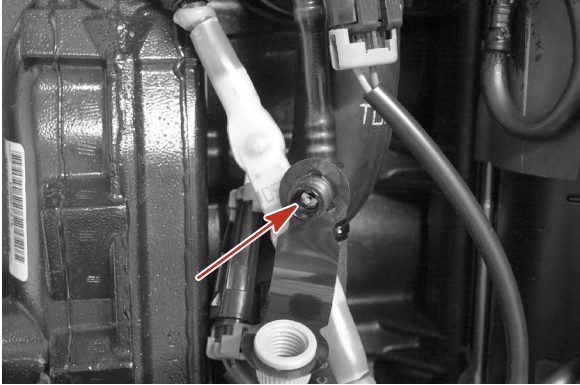

3472

4. Unscrew the filter in a counterclockwise direction to remove.

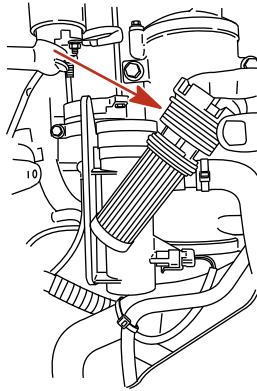

ob01253

## Filter Draining

1. Slide filter holder up to release from bracket. Hoses and wire harness can remain attached to filter holder.

# MAINTENANCE

2. Tip the filter holder to drain any fluid into an approved container.

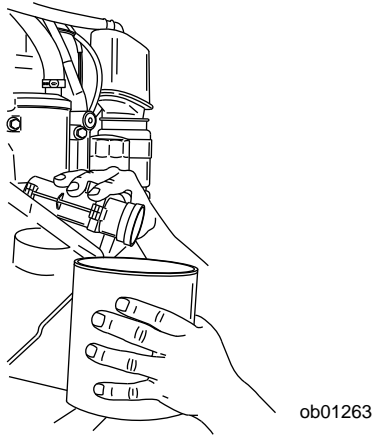

## Filter Installation

1. Position filter holder onto bracket and secure filter holder in place.
2. Lubricate the sealing ring on the filter with oil.
3. Install the filter and tighten securely by hand.

**IMPORTANT:** Visually inspect for fuel leakage from the filter while turning the ignition key to the run position, forcing fuel into the filter.

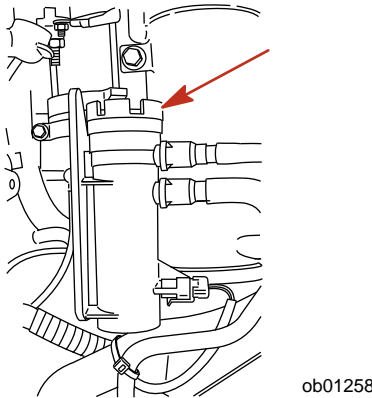

## Corrosion Control Anode

The outboard has corrosion control anodes at different locations. An anode helps protect the outboard against galvanic corrosion by sacrificing its metal to be slowly eroded instead of the outboard metals.

# MAINTENANCE

Each anode requires periodic inspection, especially in salt water which will accelerate the erosion. To maintain this corrosion protection, always replace the anode before it is completely eroded. Never paint or apply a protective coating on the anode as this will reduce effectiveness of the anode.

Two anodes are located on each side of the gearcase. Another anode is installed on the bottom of the pedestal. Two more anodes are located on the bottom of each power trim ram.

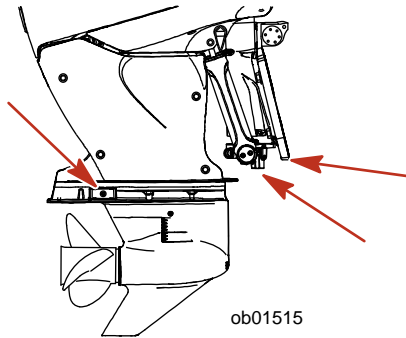

## Propeller Replacement

1. Shift outboard to neutral position.
2. Straighten the bent tabs on the propeller nut retainer.

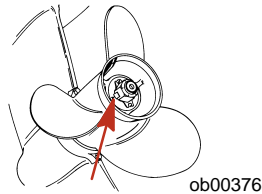

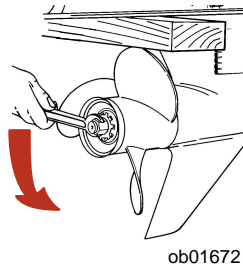

3. Place a block of wood between gearcase and propeller to hold propeller and remove propeller nut.





# MAINTENANCE

- Pull propeller straight off shaft. If propeller is seized to the shaft and cannot be removed, have the propeller removed by an authorized dealer.
- To aid in future removal of the propeller, liberally coat the propeller shaft splines with one of the following Mercury/Quicksilver products:

Tube Ref No.	Description	Where Used	Part No.
 94	Anti-Corrosion Grease	Propeller shaft splines	92-802867A1
 95	2-4-C Marine Lubricant with Teflon	Propeller shaft splines	92-802859A1

- Flo-Torq II Drive Hub Propellers** - Install forward thrust hub, replaceable drive sleeve, propeller, thrust hub, propeller nut retainer and propeller nut onto the shaft.

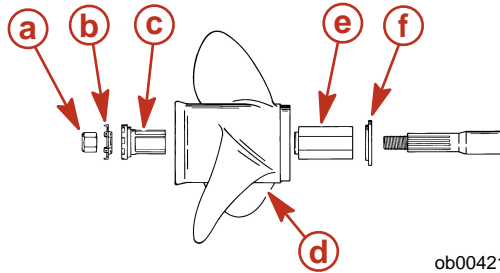

ob00421

- |                                   |                                     |
|-----------------------------------|-------------------------------------|
| <b>a</b> - Propeller nut          | <b>d</b> - Propeller                |
| <b>b</b> - Propeller nut retainer | <b>e</b> - Replaceable drive sleeve |
| <b>c</b> - Thrust hub             | <b>f</b> - Forward thrust hub       |

- Place a block of wood between gearcase and propeller and torque to specifications.

Description	Nm	lb. in.	lb. ft.
Propeller nut	75		55

# MAINTENANCE

- Secure propeller nut by bending three of the tabs into the thrust hub grooves.

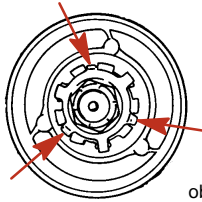

ob00422

## Spark Plug Inspection and Replacement

- Remove top and rear cowlings. Refer to **Cowl Removal and Installation**.
- Disconnect the six wiring harness connectors from pencil coil connections.
- Remove mounting bolts, using a twisting motion, and pull pencil coils from spark plugs.

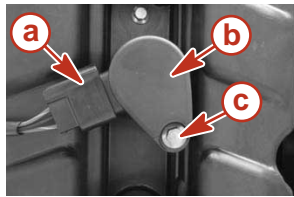

3658

- a** - Wiring harness connector      **c** - Bolt  
**b** - Pencil coil

- Remove the spark plugs to inspect. Replace spark plug if electrode is worn, threads of seal area are corroded, or the insulator is rough, cracked, broken, blistered or fouled.

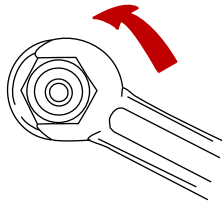

ob01092

# MAINTENANCE

- Set the spark plug gap to specifications.

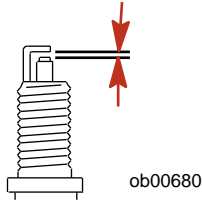

Spark Plug	
Spark Plug Gap	0.8 mm (0.0315 in.)

- Saltwater use - Apply a thin coating of Anti-Seize Compound only on threads of spark plugs.
- Clean area of spark plug seat.
- Before installing spark plugs, clean off any dirt on the spark plug seats. Install plugs finger tight, and then tighten 1/4 turn or torque to specifications.

Description	Nm	lb. in.	lb. ft.
Spark plug	27		20

- Push pencil coils into place over the spark plugs using a twisting motion.
- Secure coils with retained bolts. Torque to specifications.

Description	Nm	lb. in.	lb. ft.
Bolts	8	71	

- Connect the six wiring harness connectors to pencil coil connections.

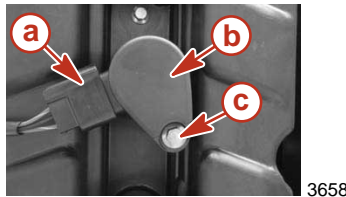

- a** - Wiring harness connector      **c** - Bolt  
**b** - Pencil coil

- Reinstall rear and top cowls.

# MAINTENANCE

## Fuses

The electrical wiring circuits on the outboard are protected from overload by fuses in the wiring. If a fuse is blown, try to locate and correct the cause of the overload. If the cause is not found, the fuse may blow again.

1. Remove top cowl. Locate fuse holder on starboard side of engine.

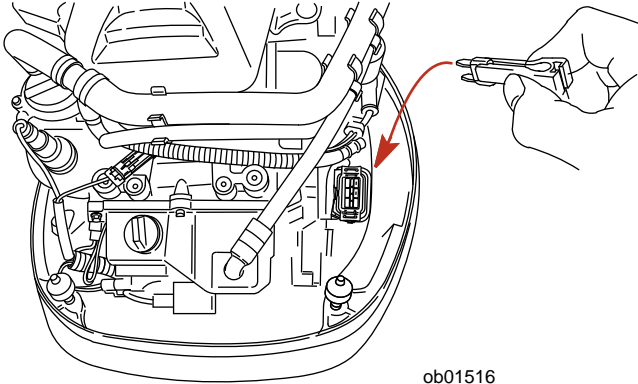

2. Remove the plastic cover from the fuse holder.
3. Remove fuse puller from fuse holder.
4. Remove suspected blown fuse to determine if the silver colored band is broken.

# MAINTENANCE

5. Replace fuse with a new fuse of the same amperage rating.

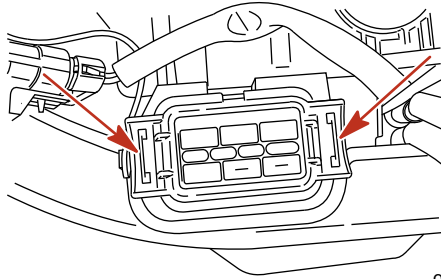

ob01252

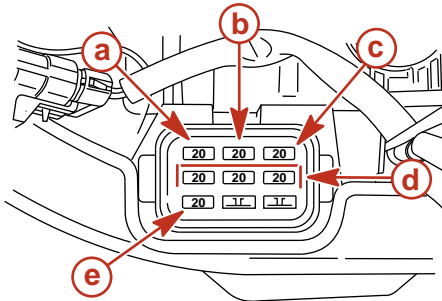

ob01259

- a** - Electronic Control Module - 20 amp fuse  
**b** - Ignition coils - 20 amp fuse  
**c** - Fuel delivery - 20 amp fuse  
**d** - Spare fuses - 20 amp fuse  
**e** - Injector power - 20 amp fuse

## DTS Wiring System

### **⚠ WARNING**

To avoid the possibility of serious injury or death from loss of boat control, do not splice or probe into any wire insulation of the DTS system. Splicing or probing will damage the wire insulation allowing water to enter the wiring. Water intrusion may lead to wiring failure and loss of throttle and shift control.

- Verify the harnesses are not routed near sharp edges, hot surfaces or moving parts.
- Verify that all unused connectors and receptacles are covered with a weather cap.
- Verify that the harnesses are fastened along the routing path.

# MAINTENANCE

## Accessory Drive Belt Inspection

Inspect the accessory drive belt and have it replaced by an authorized dealer if any of the following conditions are found.

- Cracks in the back of the belt or in the base of V grooves.
- Excessive wear at the roots of the grooves.
- Rubber portion swollen by oil.
- Belt surfaces roughened.
- Signs of wear on edges or outer surfaces of belt.

## Checking Power Trim Fluid

1. Tilt outboard to the full up position.
2. Rotate the tilt support bracket down.
3. Lower outboard until tilt support bracket rests on pedestal.
4. Remove the power trim fill cap. The fill cap only requires 1/4 turn to remove.

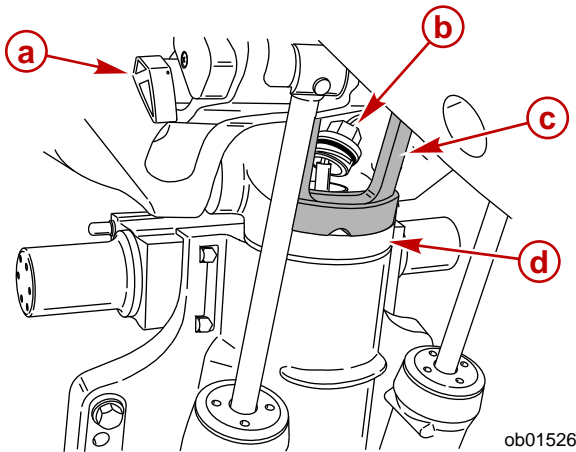

**a** - Tilt support lever

**b** - Power trim fill cap

**c** - Tilt support bracket

**d** - Pedestal

5. The fluid level should be approximately 25 mm (1 in.) from the top of the fill neck. Add Quicksilver or Mercury Precision Lubricants Power Trim & Steering Fluid. If not available, use automotive automatic transmission fluid (ATF).
6. Reinstall the power trim fill cap. Tighten fill cap 1/4 turn. Cap will snap in place. Do not tighten beyond this point.

# MAINTENANCE

## Checking Power Steering Fluid

Remove power steering cover and fill cap to check fluid level. The fluid level should be slightly below the bottom of the fill hole. Use SAE 0W-30 synthetic power steering fluid, if needed.

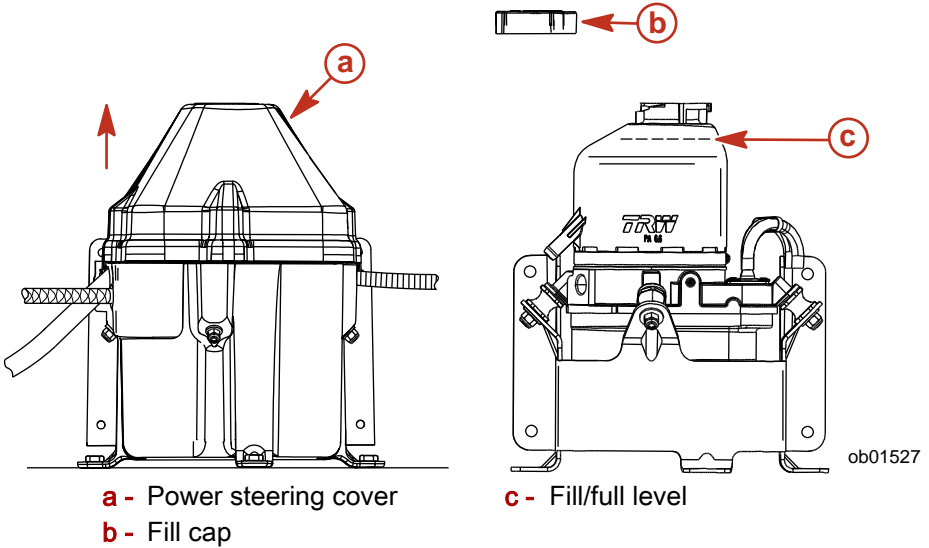

## Changing Engine Oil

### ENGINE OIL CAPACITY

Engine oil capacity is approximately 7.0 liters (7.4 quarts)

### PUMP METHOD

**IMPORTANT:** Tilt outboard out/up past vertical for approximately one minute to allow trapped oil to drain back to the oil sump.

**IMPORTANT:** To reduce or prevent oil spillage when removing the oil filter, make sure that the outboard is upright (not tilted) and the engine is cold or has not run for at least one hour.

**IMPORTANT:** The pump method is preferred to remove engine oil from XXL models. If the drain method is used, an oil drain deflector tool must be used to divert oil from the lower splash plate and into the container.

1. Tilt outboard out/up past vertical for approximately one minute to allow trapped oil to drain back to the oil sump.
2. Place the outboard in a vertical position.
3. Remove dipstick and slide adaptor tube of crankcase oil pump through oil dipstick hole, to bottom of engine oil sump.

# MAINTENANCE

4. Pump out the engine oil into an appropriate container.

## DRAIN METHOD

1. Tilt outboard out/up past vertical for approximately one minute to allow trapped oil to drain back to the oil sump.
2. Place the outboard in a vertical position.
3. Place appropriate container under engine oil sump plug. Drain plug/seal washer is located beneath the splash plate (port side of outboard).
4. Loosen drain plug/seal washer and install optional oil drain funnel over drain plug/seal washer and slide tool onto splash plate.

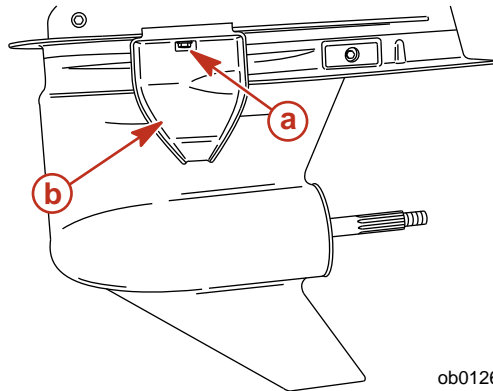

**a** - Drain plug/seal washer

**b** - Oil drain funnel

5. Remove drain plug/seal washer and drain engine oil into container.
6. Reinstall drain plug/seal washer.

## CHANGING OIL FILTER

**IMPORTANT:** To reduce or prevent oil spillage when removing the oil filter ensure that the outboard is upright (not tilted) and the engine is cold or has not run for at least one hour.

1. Remove the top cowl.
2. Place a rag or towel below the oil filter to absorb any spilled oil.



# MAINTENANCE

3. Unscrew old filter by using oil filter wrench tool and turning the filter counterclockwise.

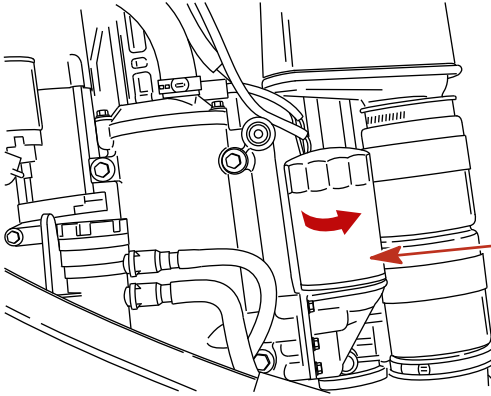

ob01251

4. Clean the oil filter mounting base.
5. Apply film of clean oil to filter gasket. Do not use grease.
6. Screw new filter on until gasket contacts base, then tighten 3/4 to 1 turn.

## OIL FILLING

1. Remove the oil fill cap and add recommended oil to the mid point of the operating range (mid point of cross hatched region). Adding approximately 7 liters (7.4 quarts) will bring oil level to mid point of cross hatched region.

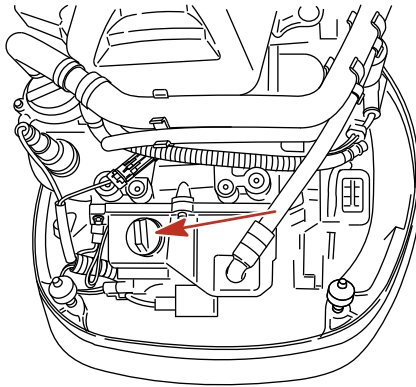

ob01250

2. Reinstall oil fill cap.
3. With outboard in water or cooling water flush hose connected, idle engine for five minutes to check for leaks at the oil filter.
4. Stop engine and check oil level. Refer to **Checking and Adding Engine Oil**.

# MAINTENANCE

## Gearcase Lubrication

When adding or changing gearcase lubricant, visually check for the presence of water in the lubricant. If water is present, it may have settled to the bottom and will drain out prior to the lubricant, or it may be mixed with the lubricant, giving it a milky colored appearance. If water is noticed, have the gearcase checked by your dealer. Water in the lubricant may result in premature bearing failure or, in freezing temperatures, will turn to ice and damage the gearcase.

Examine the drained gearcase lubricant for metal particles. A small amount of metal particles indicates normal gear wear. An excessive amount of metal filings or larger particles (chips) may indicate abnormal gear wear and should be checked by an authorized dealer.

## DRAINING GEARCASE

1. Place outboard in a vertical operating position.
2. Remove propeller. Refer to **Propeller Replacement**.
3. Place drain pan below outboard.
4. Remove vent plug and fill/drain plug and drain lubricant.

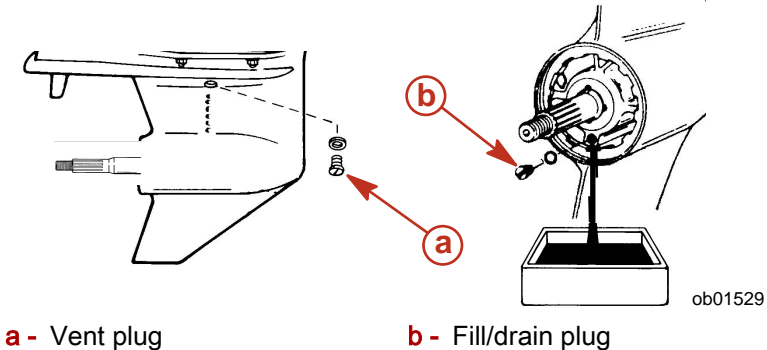

## GEARCASE LUBRICANT CAPACITY

Gearcase lubricant capacity is approximately 970 ml (32.8 fl. oz.).

## GEARCASE LUBRICANT RECOMMENDATION

Mercury or Quicksilver Premium or High Performance Gear Lubricant.

## CHECKING LUBRICANT LEVEL AND REFILLING GEARCASE

1. Place outboard in a vertical operating position.
2. Remove vent plug/sealing washer.

# MAINTENANCE

3. Remove fill/drain plug. Place lubricant tube into the fill hole and add lubricant until it appears at the vent hole.

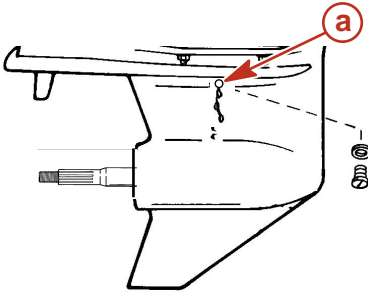

**a** - Vent hole

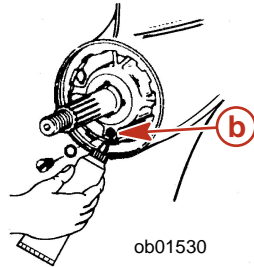

**b** - Fill hole

ob01530

**IMPORTANT: Replace sealing washers if damaged.**

4. Stop adding lubricant. Install the vent plug and sealing washer before removing the lubricant tube.
5. Remove lubricant tube and reinstall cleaned fill/drain plug and sealing washer.

# STORAGE

## Storage Preparation

The major consideration in preparing your outboard for storage is to protect it from rust, corrosion, and damage caused by freezing of trapped water.

The following storage procedures should be followed to prepare your outboard for out of season storage or prolonged storage (two months or longer).

### CAUTION

**Never start or operate your outboard (even momentarily) without water circulating through all the cooling water intake holes in the gearcase to prevent damage to the water pump (running dry) or overheating of the engine.**

## FUEL SYSTEM

**IMPORTANT:** Gasoline containing alcohol (ethanol or methanol) can cause a formation of acid during storage and can damage the fuel system. If the gasoline being used contains alcohol, it is advisable to drain as much of the remaining gasoline as possible from the fuel tank, remote fuel line, and engine fuel system.

**IMPORTANT:** This outboard is equipped with a closed fuel system when the engine is not running. With this closed system, fuel within the engine's fuel system, other than the fuel tank, will remain stable during normal storage periods without the addition of fuel treatment stabilizers.

Fill the fuel tank and engine fuel system with treated (stabilized) fuel to help prevent formation of varnish and gum. Proceed with following instructions.

- **Portable Fuel Tank** - Pour the required amount of gasoline stabilizer (follow instructions on container) into fuel tank. Tip fuel tank back and forth to mix stabilizer with the fuel.
- **Permanently Installed Fuel Tank** - Pour the required amount of gasoline stabilizer (follow instructions on container) into a separate container and mix with approximately one quart (one liter) of gasoline. Pour this mixture into fuel tank.

## Protecting External Outboard Components

- Touch up any paint nicks. See your dealer for touch-up paint.
- Spray Quicksilver or Mercury Precision Lubricants Corrosion Guard on external metal surfaces (except corrosion control anodes).

# STORAGE

## Protecting Internal Engine Components

**IMPORTANT:** Refer to Maintenance - Spark Plug Inspection and Replacement for correct procedure for removing spark plugs.

- Remove pencil coils and spark plugs.
- Spray approximately 30 ml (1 fl. oz.) of Storage Seal Rust Inhibitor into each spark plug hole.
- Actuate key/push button start switch to crank the engine through one start cycle, which will distribute the storage seal throughout the cylinders.
- Reinstall spark plugs and pencil coils.

## Gearcase

- Drain and refill the gearcase lubricant (refer to Maintenance - Gearcase Lubrication).

## Positioning Outboard For Storage

Store outboard in an upright (vertical) position to allow water to drain out of outboard.

### CAUTION

If outboard is stored tilted up in freezing temperature, trapped cooling water or rain water that may have entered the propeller exhaust outlet in the gearcase could freeze and cause damage to the outboard.

## Battery Storage

- Follow the battery manufacturer's instructions for storage and recharging.
- Remove the battery from the boat and check water level. Recharge if necessary.
- Store the battery in a cool, dry place.
- Periodically check the water level and recharge the battery during storage.

# TROUBLESHOOTING

## Starter Motor Will Not Crank the Engine

### POSSIBLE CAUSES

- Lanyard stop switch not in "RUN" position.
- Blown 5 Amp fuse. Check DTS power harness circuit fuse. Refer to **Maintenance** section.
- Outboard is not shifted to neutral position.
- Shift actuator failure. "Gear Shift Diff" error message shown on System View. Refer to **Maintenance** section.
- Weak battery or battery connections are loose or corroded.
- Ignition key switch failure.
- Wiring or electrical connection faulty.
- Starter motor solenoid or slave solenoid failure.

## Engine Will Not Start

### POSSIBLE CAUSES

- Incorrect starting procedure. Refer to **Operation** section.
- Old or contaminated gasoline.
- Fuel is not reaching the engine.
  - Fuel tank is empty.
  - Fuel tank vent not open or restricted.
  - Fuel line is disconnected or kinked.
  - Fuel filter is obstructed. Refer to **Maintenance** section.
  - Fuel pump failure.
  - Fuel tank filter obstructed.
- Ignition system component failure.
- Spark plugs fouled or defective. Refer to **Maintenance** section.

## Engine Starts But Will Not Shift Into Gear

- Shift actuator failure. "Gear Shift Diff" error message shown on System View. Refer to **Maintenance** section.

## Engine Runs Erratically

### POSSIBLE CAUSES

- Overheating - Warning horn not working.
- Low oil pressure. Check oil level.
- Spark plugs fouled or defective. Refer to **Maintenance** section.
- Incorrect setup and adjustments.

# TROUBLESHOOTING

- Fuel is being restricted to the engine.
  - a. Engine fuel filter is obstructed. Refer to **Maintenance** section.
  - b. Fuel tank filter obstructed.
  - c. Stuck anti-siphon valve located on permanently built-in type fuel tanks.
  - d. Fuel line is kinked or pinched.
- Fuel pump failure.
- Ignition system component failure.

## Performance Loss

### POSSIBLE CAUSES

- Overheating - Warning horn not working.
- Low oil pressure. Check oil level.
- Throttle not opening fully.
- Damaged propeller or improper propeller size.
- Incorrect engine timing, adjustment, or setup.
- Boat overloaded or load improperly distributed.
- Excessive water in bilge.
- Boat bottom is dirty or damaged.

## Battery Will Not Hold Charge

### POSSIBLE CAUSES

- Battery connections are loose or corroded.
- Low electrolyte level in battery.
- Worn out or inefficient battery.
- Excessive use of electrical accessories.
- Defective rectifier, alternator, or voltage regulator.
- Open circuit in the alternator output wire (fused link).

# OWNER SERVICE ASSISTANCE

## Local Repair Service

Always return your outboard to your local authorized dealer should the need for service arise. Only he has the factory trained mechanics, knowledge, special tools, equipment, and genuine parts and accessories to properly service your engine should the need occur. He knows your engine best.

## Service Away From Home

If you are away from your local dealer and the need arises for service, contact the nearest authorized dealer. Refer to the Yellow Pages of the telephone directory. If, for any reason, you cannot obtain service, contact the nearest Mercury Marine Service Office.

## Parts And Accessories Inquiries

All inquiries concerning genuine replacement parts and accessories should be directed to your local authorized dealer. The dealer has the necessary information to order parts and accessories for you. When inquiring on parts and accessories, the dealer requires the model and serial number to order the correct parts.

## Service Assistance

Your satisfaction with your outboard product is very important to your dealer and to us. If you ever have a problem, question or concern about your outboard product, contact your dealer or any authorized Mercury Marine dealership. If additional assistance is required, take these steps.

1. Talk with the dealership's sales manager or service manager. If this has already been done, then contact the owner of the dealership.
2. Should you have a question, concern, or problem that cannot be resolved by your dealership, please contact Mercury Marine Service Office for assistance. Mercury Marine will work with you and your dealership to resolve all problems.

The following information will be needed by the service office:

- Your name and address
- Daytime telephone number
- Model and serial number of your outboard
- The name and address of your dealership
- Nature of problem



# OWNER SERVICE ASSISTANCE

## Mercury Marine Service Offices

For assistance, call, fax, or write. Please include your daytime telephone number with mail and fax correspondence.

<b>United States</b>		
Telephone	(920) 929-5040	Mercury Marine W6250 W. Pioneer Road P.O. Box 1939 Fond du Lac, WI 54936-1939
Fax	(920) 929-5893	
Website	www.mercurymarine.com	

<b>Canada</b>		
Telephone	(905) 567-6372	Mercury Marine Ltd. 2395 Meadowpine Blvd. Mississauga, Ontario L5N 7W6 Canada
Fax	(905) 567-8515	

<b>Australia, Pacific</b>		
Telephone	(61) (3) 9791-5822	Mercury Marine Australia 132-140 Frankston Road Dandenong, Victoria 3164 Australia
Fax	(61) (3) 9793-5880	

<b>Europe, Middle East, Africa</b>		
Telephone	(32) (87) 32 • 32 • 11	Marine Power - Europe, Inc. Parc Industriel de Petit-Rechain B-4800 Verviers, Belgium
Fax	(32) (87) 31 • 19 • 65	

<b>Mexico, Central America, South America, Caribbean</b>		
Telephone	(954) 744-3513	Mercury Marine 11650 Interchange Circle North Miramar, FL 33025 U.S.A.
Fax	(954) 744-3535	

## OWNER SERVICE ASSISTANCE

<b>Japan</b>		
Telephone	81-053-423-2500	Mercury Marine - Japan Anshin-cho 283-1 Hamamatsu Shizuoka-ken, Japan 435-0005 Japan
Fax	81-053-423-2510	

<b>Asia, Singapore</b>		
Telephone	5466160	Mercury Marine Singapore 72 Loyang Way Singapore, 508762
Fax	5467789	

# MAINTENANCE LOG

## Maintenance Log

Record all maintenance performed on your outboard here. Be sure to save all work orders and receipts.

Date	Maintenance Performed	Engine Hours